



TRUSSING



INHALTSVERZEICHNIS | TABLE OF CONTENT

ÜBER UNS

Bereits seit dem Jahr 2000 fertigt Global Truss Produkte aus Aluminium. Global Truss Produkte sind mittlerweile in mehr als 50 Ländern verfügbar und Global Truss Kunden wissen die hervorragende Lieferfähigkeit und Qualität sehr zu schätzen.

Qualität, Zuverlässigkeit, Innovation und Verfügbarkeit – diese vier Schlagworte sind als Leitprinzipien der Global Truss Firmenphilosophie fest verankert.

Mit über 120 Mitarbeitern weltweit ist Global Truss mittlerweile zu einem der Marktführer im Traversenbusiness gewachsen. Neben dem Hauptsitz in Taiwan und Logistikhubs in der ganzen Welt hat Global Truss seit 2017 auch einen europäischen Standort in Deutschland.

ABOUT US

Since the year 2000 Global Truss has been manufacturing and providing trusses and accessories. Global Truss products are now available in more than 50 countries and Global Truss customers appreciate the excellent availability and quality of its products.

Quality, reliability, innovation and availability - these four keywords are the guiding principles of the Global Truss company philosophy.

With more than 120 employees worldwide Global Truss has now grown to one of the leading truss manufacturers. Apart from its headquarter in Taiwan and its logistic hubs around the world, Global Truss opened a European headquarter in Germany in 2017.

F14	S. 04	Multi-Tower-Basement	S. 70
F22	S. 08	Groundsupport	S. 72
F23	S. 13	Towerlift	S. 74
F24	S. 16	Babytower	S. 76
F31 (PL) / Stage Black	S. 20	Juniortower	S. 78
U-Top / U-Frame	S. 24	F42	S. 80
F32 Stage Black	S. 26 S. 30	F43	S. 84
F33 Stage Black	S. 34 S. 40	F44	S. 88
F33PL Stage Black	S. 42 S. 46	F44P Stage Black	S. 92 S. 96
F34 Stage Black	S. 50 S. 54	F45	S. 98
Tower Tools	S. 56	F54	S. 100
F34P Stage Black	S. 58 S. 60	F52	S. 102
F34PL Stage Black	S. 62 S. 66	F102	S. 104
Sleeve	S. 68	i-M Type	S. 106
		i-L Type	S. 108
		Zubehör / Accessories	S. 112

F14



Das F14 Traversensystem von Global Truss ist ein TÜV-geprüftes 4-Punkt System mit einem Außenmaß von 10cm. Die kleine Bauweise der Traversen eignet sich ideal für den Ladenbau und kleine Konstruktionen mit geringer Belastung. Es sind Spannweiten bis zu 7 Meter möglich.

Die F14 Traverse ist aus 20x2 mm Gurtrohren und 6 mm Diagonalbracings aus Aluminium gefertigt. Ein zusätzlicher Endrahmen steigert die Stabilität der Traverse. Die Traversen werden über konische Verbinder, welche im Lieferumfang enthalten sind, miteinander verbunden. Wie alle Global Truss Traversen lässt sich auch diese in beliebigen Farben pulverbeschichten.

The F14 truss series by Global Truss is a TÜV approved 4-point system with an external dimension of 10cm. The small footprint of the truss is perfect for shop fitting and constructions with minimal loads. A maximum span of up to 7 meters can be used.

The F14 truss is built with 20 x 2mm main tubes and 6mm diagonal braces of aluminium, whilst the extra end frame improves the stability of the truss. The truss lengths are connected with the included conical connectors. This truss and all other Global Truss series can be powder coated in every RAL colour.

TECHNISCHE DATEN

Rohrdurchmesser Hauptrohr:	20 mm
Wandstärke:	2 mm
Material:	Al EN AW-6061 T6
Eingeschweißte Schlange	6 mm
Konische Verbinder	im Lieferumfang enthalten

TECHNICAL DATA

Pipe diameter:	20 mm
Wall thickness:	2 mm
Material:	Al EN AW-6061 T6
Snake brace	6 mm
Connectors	included



GERADEN | STRAIGHTS ALU NATURAL

CODE	Länge length	Gewicht weight
F14050	50 cm	1,0 kg
F14100	100 cm	2,0 kg
F14150	150 cm	3,0 kg
F14200	200 cm	4,0 kg
F14250	250 cm	5,0 kg
F14300	300 cm	6,0 kg



GERADEN | STRAIGHTS STAGE BLACK

CODE	Länge length	Gewicht weight
F14050-B	50 cm	1,0 kg
F14100-B	100 cm	2,0 kg
F14150-B	150 cm	3,0 kg
F14200-B	200 cm	4,0 kg
F14250-B	250 cm	5,0 kg
F14300-B	300 cm	6,0 kg



KREISSTÜCKE | CIRCLE PARTS

CODE	Ø Kreis/circle	Kreisstück/circle part	Gewicht/weight
F14R10-90	2,0 m	1 Stück 90°	2,4 kg
F14R15-90	3,0 m	1 Stück 90°	3,6 kg
F14R20-45	4,0 m	1 Stück 45°	3,1 kg

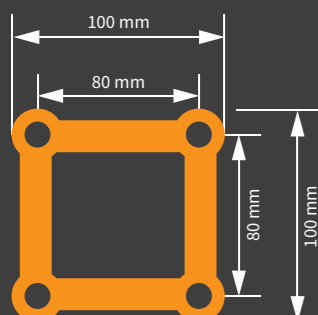

LOAD TABLE

Span	Uniform distribution load		Center point load		Point load in third-point		Point load in quarter-point		Point load in fifth-point	
	kg / m	Deflection cm	kg	Deflection cm	kg	Deflection cm	kg	Deflection cm	kg	Deflection cm
2,00	104,00	0,43	172,00	0,56	104,00	0,58	69,00	0,54	52,00	0,51
3,00	69,00	1,44	113,00	1,27	85,00	1,61	57,00	1,50	47,00	1,59
4,00	42,00	2,81	84,00	2,27	63,00	2,87	42,00	2,67	35,00	2,83
5,00	26,00	4,40	65,00	3,58	49,00	4,49	33,00	4,19	27,00	4,43
6,00	18,00	6,35	53,00	5,21	40,00	6,48	26,00	6,07	22,00	6,40
7,00	12,00	8,68	43,00	7,18	33,00	8,85	22,00	8,31	18,00	8,74

Das Eigengewicht der Traverse ist in der Belastungstabelle berücksichtigt.
The dead load of the truss is considered in the load table.

BODENPLATTE | BASE PLATE

CODE F14BASE	alu natural
CODE F14BASE-B	black



0,25 KG 40 100

BASE SQUARE

250mm quadratisch / square
CODE F14BASESQUARE



1,0 KG 40 250

BASE RUND | BASE ROUND

250mm Durchmesser / diameter
CODE F14BASEROUND



1,0 KG 40 250

SPACER FEMALE

F14S050	50 mm	alu natural
F14S105	105 mm	alu natural
F14S170	170 mm	alu natural
F14S210	210 mm	alu natural
F14S105-B	105 mm	black
F14S170-B	170 mm	black
F14S210-B	210 mm	black



VARIABLER WINKEL | CORNER

CODE F14BC alu natural
CODE F14BC-BLACK black



0,35 kg
150
100 70

BOX CORNER

CODE F14BOX alu natural
CODE F14BOX-B black



0,9 kg
100 100 100

HALBKONUS FÜR BOXCORNER
HALFCONNECTOR FOR BOXCORNER
CODE F14BOXC



KONUSVERBINDER
CONICAL CONNECTOR
CODE F14CON



STAHLSTIFT mit Sicherungsplint
STEELPIN with R-clip
CODE F14BOLT

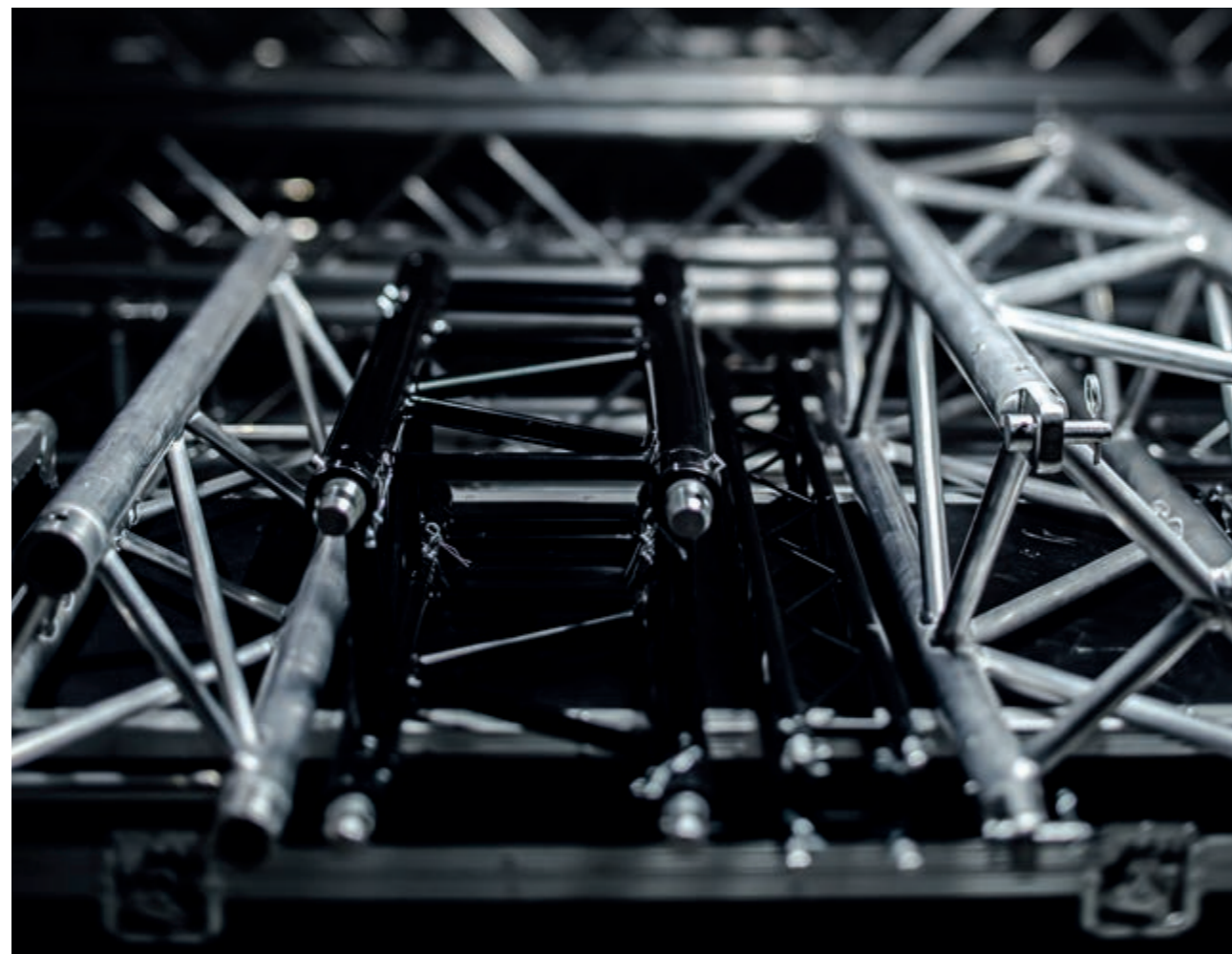

F22



Das F22 Traversensystem von Global Truss ist ein TÜV-geprüftes 2-Punkt System mit einem Außenmaß von 22 cm. Kleinere Konstruktionen mit geringer Belastung im Verbund als Rasterdecke (Grid) für Messestände und Festinstallationen lassen sich mit diesem System ideal realisieren. Im Gridverbund sind so Spannweiten bis 7 Meter möglich.

Die F22 Traverse ist aus 35x1,6 mm Gurtrohren und 8mm Diagonalbracings aus Aluminium gefertigt. Verbunden werden die Traversen mit konischen Verbindern, welche im Lieferumfang enthalten sind. Wie alle Global Truss Traversen lässt sich auch diese in beliebigen Farben pulverbeschichten.

The F22 truss series by Global Truss is a TÜV approved 2-point system with an external dimension of 22cm. The series is perfect for small constructions with a low load for exhibition stands and permanent installations. A maximum span of up to 7 meters can be used.

The F22 truss is built with 35 x 1.6mm main tubes and 8mm diagonal braces of aluminium. The truss lengths are connected with the included conical connectors. This truss and all other Global Truss series can be powder coated in every RAL colour.

TECHNISCHE DATEN

Rohrdurchmesser Hauptrohr: 35 mm
 Wandstärke: 1,6 mm
 Material: Al EN AW-6061 T6
 Eingeschweißte Schlange: 8 mm
 Konische Verbinder: enthalten

TECHNICAL DATA

Pipe diameter: 35 mm
 Wall thickness: 1,6 mm
 Material: Al EN AW-6061 T6
 Snake brace: 8 mm
 Connectors: included

GERADEN | STRAIGHTS

CODE	Länge length	Gewicht weight
F22050	50 cm	1,0 kg
F22100	100 cm	1,5 kg
F22150	150 cm	2,0 kg
F22200	200 cm	2,7 kg
F22250	250 cm	3,2 kg
F22300	300 cm	3,8 kg
F22350	350 cm	4,3 kg
F22400	400 cm	4,9 kg
F22450	450 cm	5,5 kg
F22500	500 cm	6,0 kg

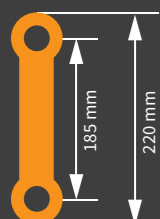

LOAD TABLE

Span	Uniform distribution load		Center point load		point load in third-point	
	kg / m	Deflection cm	kg	Deflection cm	kg	Deflection cm
2,00	66,00	0,07	132,00	0,11	66,00	0,09
3,00	44,00	0,23	131,00	0,37	65,00	0,31
4,00	32,00	0,55	129,00	0,87	65,00	0,74
5,00	26,00	1,08	103,00	1,37	64,00	1,45
6,00	21,00	1,87	85,00	1,98	63,00	2,50
7,00	18,00	2,97	71,00	2,72	53,00	3,41
2,00	66,00	0,07	132,00	0,11	66,00	0,09
3,00	44,00	0,23	91,00	0,26	65,00	0,31
4,00	32,00	0,55	67,00	0,46	50,00	0,58
5,00	21,00	0,90	52,00	0,73	39,00	0,91
6,00	14,00	1,29	42,00	1,06	32,00	1,32
7,00	10,00	1,77	35,00	1,46	26,00	1,80
1,00	133,00	0,01	133,00	0,01	67,00	0,01
1,50	88,00	0,03	133,00	0,05	66,00	0,04
2,00	66,00	0,07	81,00	0,07	61,00	0,09
2,50	33,00	0,09	42,00	0,07	31,00	0,09
3,00	16,00	0,09	23,00	0,07	17,00	0,09

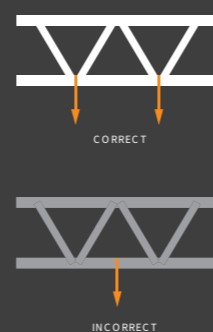

(*) values only valid if the load burdens the junction:

Compression chord held every 0.5m!

Das Eigengewicht der Traverse ist in der Belastungstabelle berücksichtigt.
 The dead load of the truss is considered in the load table.

BODENPLATTE | BASE PLATE CODE F22BASE



1,0 kg

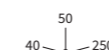

45° ECKE | CORNER C19 H CODE F22C19H



3,2 kg

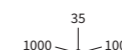

45° ECKE | CORNER C19 V CODE F22C19V



3,2 kg

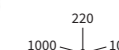

60° ECKE | CORNER C20 H CODE F22C20H



3,2 kg

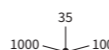

60° ECKE | CORNER C20 V CODE F22C20V



3,2 kg

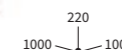

90° ECKE | CORNER C21 H CODE F22C21H



2,2 kg

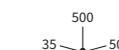

90° ECKE | CORNER C21 V
CODE F22C21V



2,2 kg 220
500 ↙ ↘ 500

120° ECKE | CORNER C22 H
CODE F22C22H



2,2 kg 35
500 ↙ ↘ 500

120° ECKE | CORNER C22 V
CODE F22C22V



2,2 kg 220
500 ↙ ↘ 500

4-WEG ECKE | 4-WAY CORNER T42 H
CODE F22T42H



2,1 kg 500
220 ↙ ↘ 500

4-WEG ECKE | 4-WAY CORNER T42 V
CODE F22T42V



2,1 kg 220
500 ↙ ↘ 500

135° ECKE | CORNER C23 H
CODE F22C23H



2,2 kg 35
500 ↙ ↘ 500

135° ECKE | CORNER C23 V
CODE F22C23V



2,2 kg 220
500 ↙ ↘ 500

3-WEG ECKE | 3-WAY CORNER C31 H
CODE F22C31H



3,4 kg 500
500 ↙ ↘ 500

KREISSTÜCKE | CIRCLE PARTS HORIZONTAL

CODE	Ø Kreis/circle	Kreisstück/circle part	Gewicht/weight
F22R10-180H	2,0 m	1 Stück 180°	3,9 kg
F22R15-90H	3,0 m	1 Stück 90°	3,3 kg
F22R20-90H	4,0 m	1 Stück 90°	3,9 kg
F22R25-60H	5,0 m	1 Stück 60°	3,6 kg
F22R30-60H	6,0 m	1 Stück 60°	4,1 kg
F22R35-45H	7,0 m	1 Stück 45°	3,5 kg
F22R40-45H	8,0 m	1 Stück 45°	4,0 kg
F22R45-45H	9,0 m	1 Stück 45°	4,3 kg
F22R50-30H	10,0 m	1 Stück 30°	3,4 kg



3-WEG ECKE | 3-WAY CORNER C31 V
CODE F22C31V



3,4 kg 500
500 ↙ ↘ 500

X-STÜCK | JOINT C41 H
CODE F22C41H



1,7 kg 500
35 ↙ ↘ 500

X-STÜCK | JOINT C41 V
CODE F22C41V



2,5 kg 220
500 ↙ ↘ 500

KREISSTÜCKE | CIRCLE PARTS VERTIKAL

CODE	Ø Kreis/circle	Kreisstück/circle part	Gewicht/weight
F22R10-180V	2,0 m	1 Stück 180°	3,9 kg
F22R15-90V	3,0 m	1 Stück 90°	3,3 kg
F22R20-90V	4,0 m	1 Stück 90°	3,9 kg
F22R25-60V	5,0 m	1 Stück 60°	3,6 kg
F22R30-60V	6,0 m	1 Stück 60°	4,1 kg
F22R35-45V	7,0 m	1 Stück 45°	3,5 kg
F22R40-45V	8,0 m	1 Stück 45°	4,0 kg
F22R45-45V	9,0 m	1 Stück 45°	4,3 kg
F22R50-30V	10,0 m	1 Stück 30°	3,4 kg



3-WEG ECKE | 3-WAY CORNER T36 H
CODE F22T36H



1,7 kg 500
35 ↙ ↘ 500

3-WEG ECKE | 3-WAY CORNER T36 V
CODE F22T36V



1,7 kg 220
500 ↙ ↘ 500

6-ECKWÜRFEL | CUBE
CODE 5006B
M8 Gewinde / M8 thread



Halbkonus | Half connector
Seite | page 153
0,3 kg 38
38 ↙ ↘ 38



F23

Das F23 Traversensystem von Global Truss ist ein TÜV-geprüftes 3-Punkt System mit einem Außenmaß von 22cm. Kleine Messestände, Bannerrahmen aber auch Deckenkonstruktionen zur Anbringung von Licht- und Tonanlagen werden hiermit realisiert. Auch im Ladenbau findet dieses System oft seinen Einsatz. Spannweiten bis zu 10m sind möglich.

Die F23 Traverse ist gefertigt mit 35x1,6mm Gurtrohren und 8mm Diagonalbracings aus Aluminium. Verbunden werden die Traversen mit konischen Verbindern, welche im Lieferumfang enthalten sind. Wie alle Global Truss Traversen lässt sich auch diese in beliebigen Farben pulverbeschichten.

The F23 truss series by Global Truss is a TÜV approved 3-point system with an external dimension of 22cm. The series is perfect for small constructions, banner frames or permanent installations for lighting and sound along with use in shops. A maximum span of up to 10 meters can be used.

The F23 truss is built with 35 x 1.6mm main tubes and 8mm diagonal braces of aluminium. The truss lengths are connected with the included conical connectors. This truss and all other Global Truss series can be powder coated in every RAL colour.



TECHNISCHE DATEN

Rohrdurchmesser Hauptrohr:	35 mm
Wandstärke:	1,6 mm
Material:	Al EN AW-6061 T6
Eingeschweißte Schlange	8 mm
Konische Verbinder	enthalten

TECHNICAL DATA

Pipe diameter:	35 mm
Wall thickness:	1,6 mm
Material:	Al EN AW-6061 T6
Snake brace	8 mm
Connectors	included



GERADEN | STRAIGHTS

CODE	Länge length	Gewicht weight
F23050	50 cm	1,7 kg
F23100	100 cm	3,0 kg
F23150	150 cm	4,2 kg
F23200	200 cm	5,5 kg
F23250	250 cm	7,0 kg
F23300	300 cm	8,0 kg
F23350	350 cm	9,5 kg
F23400	400 cm	10,3 kg
F23450	450 cm	11,1 kg
F23500	500 cm	13,0 kg



KREISSTÜCKE | CIRCLE PARTS

CODE	Ø Kreis circle	Kreisstück circle part	Gewicht weight
F23R05-180	1,0 m	1 Stück 180°	4,3 kg
F23R075-90	1,5 m	1 Stück 90°	3,4 kg
F23R10-180	2,0 m	1 Stück 180°	8,2 kg
F23R15-90	3,0 m	1 Stück 90°	6,3 kg
F23R20-90	4,0 m	1 Stück 90°	8,5 kg
F23R25-60	5,0 m	1 Stück 60°	7,1 kg
F23R30-60	6,0 m	1 Stück 60°	8,5 kg
F23R35-60	7,0 m	1 Stück 60°	9,9 kg
F23R40-60	8,0 m	1 Stück 60°	11,3 kg
F23R45-60	9,0 m	1 Stück 60°	12,7 kg
F23R50-30	10,0 m	1 Stück 30°	10,6 kg

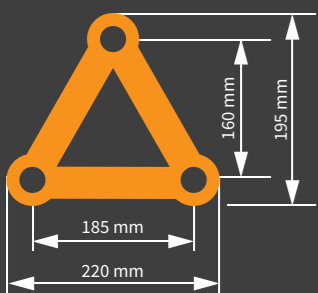

LOAD TABLE

Span	Uniform distribution load		Center point load		Point load in third-point		Point load in quarter-point		Point load in fifth-point	
	kg / m	Deflection	kg	Deflection	kg	Deflection	kg	Deflection	kg	Deflection
2,00	65,00	0,07	129,00	0,11	65,00	0,09	43,00	0,09	32,00	0,08
3,00	42,00	0,23	127,00	0,36	63,00	0,31	42,00	0,29	32,00	0,28
4,00	31,00	0,55	124,00	0,85	62,00	0,73	41,00	0,68	31,00	0,65
5,00	24,00	1,07	121,00	1,65	61,00	1,42	40,00	1,33	30,00	1,28
6,00	20,00	1,86	118,00	2,83	59,00	2,45	39,00	2,29	30,00	2,20
7,00	17,00	2,96	100,00	3,93	58,00	3,87	39,00	3,63	29,00	3,49
8,00	14,00	4,43	86,00	5,22	57,00	5,76	38,00	5,41	28,00	5,20
9,00	12,00	6,32	74,00	6,71	55,00	8,17	37,00	7,68	28,00	7,39
10,00	11,00	8,69	65,00	8,42	48,00	10,23	33,00	9,77	27,00	10,12

Das Eigengewicht der Traverse ist in der Belastungstabelle berücksichtigt.
The dead load of the truss is considered in the load table.

BODENPLATTE | BASE PLATE



45° ECKE | CORNER C19



60° ECKE | CORNER C20



90° ECKE | CORNER C21
CODE F23C21

2,1 kg

195
500 ↙ ↘
500

120° ECKE | CORNER C22
CODE F23C22

2,3 kg

195
500 ↙ ↘
500

135° ECKE | CORNER C23
CODE F23C23

2,6 kg

195
500 ↙ ↘
500

5-WEG ECKE | 5-WAY CORNER C52
CODE F23C52

4,0 kg

500
500 ↙ ↘
500

5-WEG ECKE | 5-WAY CORNER C53
CODE F23C53

4,0 kg

500
500 ↙ ↘
500

3-WEG ECKE | 3-WAY CORNER T35
CODE F23T35

2,6 kg

500
220 ↙ ↘
500

90° ECKE | CORNER C24
CODE F23C24

2,0 kg

500
220 ↙ ↘
500

90° ECKE | CORNER C25
CODE F23C25

2,2 kg

500
220 ↙ ↘
500

3-WEG ECKE | 3-WAY CORNER C31
CODE F23C31

3,2 kg

500
500 ↙ ↘
500

3-WEG ECKE | 3-WAY CORNER T36
CODE F23T36

2,6 kg

220
500 ↙ ↘
500

3-WEG ECKE | 3-WAY CORNER T37
CODE F23T37

2,7 kg

500
220 ↙ ↘
500

3-WEG ECKE | 3-WAY CORNER T38
CODE F23T38

2,8 kg

500
220 ↙ ↘
500

3-WEG ECKE | 3-WAY CORNER C32
CODE F23C32

3,0 kg

500
500 ↙ ↘
500

3-WEG ECKE | 3-WAY CORNER C33
CODE F23C33

3,5 kg

500
500 ↙ ↘
500

3-WEG ECKE | 3-WAY CORNER C34
CODE F23C34

3,5 kg

500
500 ↙ ↘
500

3-WEG ECKE | 3-WAY CORNER T39
CODE F23T39

3,0 kg

500
220 ↙ ↘
500

4-WEG ECKE | 4-WAY CORNER T42
CODE F23T42

3,3 kg

500
500 ↙ ↘
500

4-WEG ECKE | 4-WAY CORNER T43
CODE F23T43

3,3 kg

500
500 ↙ ↘
500

4-WEG ECKE | 4-WAY CORNER C41
CODE F23C41

2,7 kg

220
500 ↙ ↘
500

4-WEG ECKE | 4-WAY CORNER C44
CODE F23C44

4,5 kg

500
500 ↙ ↘
500

4-WEG ECKE | 4-WAY CORNER C45
CODE F23C45

3,1 kg

500
500 ↙ ↘
500

4-WEG ECKE | 4-WAY CORNER T47
CODE F23T47

3,3 kg

500
220 ↙ ↘
500

5-WEG ECKE | 5-WAY CORNER T51
CODE F23T51

3,9 kg

500
500 ↙ ↘
500

6-WEG ECKE | 6-WAY CORNER T61
CODE F23T61

4,2 kg

500
500 ↙ ↘
500

F24

Das F24 Traversensystem von Global Truss ist ein TÜV-geprüftes 4-Punkt System mit einem Außenmaß von 22cm. Kleine Messestände, Bannerrahmen aber auch Deckenkonstruktionen zur Anbringung von Licht- und Tonanlagen werden hiermit realisiert. Auch im Ladenbau findet dieses System oft seinen Einsatz. Spannweiten bis zu 10m sind möglich.

Die F24 Traverse ist gefertigt mit 35x1,6mm Gurtrohren und 8mm Diagonalbracings aus Aluminium. Ein zusätzlicher Endrahmen steigert die Stabilität der Traverse. Verbunden werden die Traversen mit konischen Verbindern, welche im Lieferumfang enthalten sind. Wie alle Global Truss Traversen lässt sich auch diese in beliebigen Farben pulverbeschichten.

The F24 truss series by Global Truss is a TÜV approved 4-point system with an external dimension of 22cm. The series is perfect for small constructions, banner frames or permanent installations for lighting and sound along with use in shops. A maximum span of up to 10 meters can be used.

The F24 truss is built with 35 x 1.6mm main tubes and 8mm diagonal braces of aluminium. The truss lengths are connected with the included conical connectors. This truss and all other Global Truss series can be powder coated in every RAL colour.



TECHNISCHE DATEN

Rohrdurchmesser Hauptrohr: 35 mm
 Wandstärke: 1,6 mm
 Material: Al EN AW-6061 T6
 Eingeschweißte Schlange: 8 mm
 Konische Verbinder: enthalten

TECHNICAL DATA

Pipe diameter: 35 mm
 Wall thickness: 1,6 mm
 Material: Al EN AW-6061 T6
 Snake brace: 8 mm
 Connectors: included



GERADEN | STRAIGHTS

CODE	Länge length	Gewicht weight
F24050	50 cm	2,1 kg
F24100	100 cm	3,5 kg
F24150	150 cm	4,8 kg
F24200	200 cm	6,1 kg
F24250	250 cm	7,4 kg
F24300	300 cm	8,8 kg
F24350	350 cm	10,1 kg
F24400	400 cm	11,4 kg
F24450	450 cm	12,7 kg
F24500	500 cm	14,0 kg



Mit stabiler Endplatte
With solid endplate

KREISSTÜCKE | CIRCLE PARTS VERTIKAL

CODE	Ø Kreis/circle	Kreisstück/circle part	Gewicht/weight
F24R05-180	1,0 m	1 Stück 180°	4,5 kg
F24R10-180	2,0 m	1 Stück 180°	8,7 kg
F24R15-90	3,0 m	1 Stück 90°	8,3 kg
F24R20-90	4,0 m	1 Stück 90°	10,9 kg
F24R25-60	5,0 m	1 Stück 60°	13,7 kg
F24R30-60	6,0 m	1 Stück 60°	16,5 kg
F24R35-45	7,0 m	1 Stück 45°	12,8 kg
F24R40-45	8,0 m	1 Stück 45°	14,6 kg
F24R45-45	9,0 m	1 Stück 45°	16,5 kg
F24R50-30	10,0 m	1 Stück 30°	13,7 kg

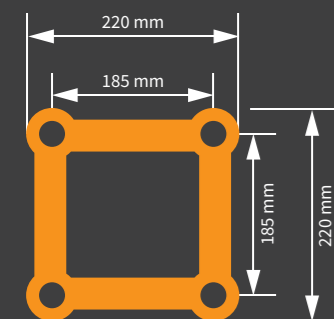

LOAD TABLE

Span	Uniform distribution load		Center point load		Point load in third-point		Point load in quarter-point		Point load in fifth-point	
	kg / m	Deflection cm	kg	Deflection cm	kg	Deflection cm	kg	Deflection cm	kg	Deflection cm
2,00	131,00	0,07	263,00	0,11	131,00	0,09	88,00	0,09	66,00	0,08
3,00	87,00	0,23	260,00	0,37	130,00	0,31	87,00	0,29	65,00	0,28
4,00	64,00	0,55	257,00	0,86	129,00	0,74	86,00	0,69	64,00	0,66
5,00	51,00	1,07	255,00	1,68	127,00	1,44	85,00	1,34	64,00	1,29
6,00	42,00	1,86	252,00	2,90	126,00	2,48	84,00	2,32	63,00	2,22
7,00	36,00	2,95	233,00	4,31	125,00	3,94	83,00	3,68	62,00	3,52
8,00	31,00	4,41	204,00	5,72	123,00	5,87	82,00	5,48	62,00	5,25
9,00	27,00	6,29	181,00	7,34	122,00	8,34	81,00	7,79	61,00	7,47
10,00	24,00	8,63	161,00	9,17	117,00	11,15	80,00	10,68	60,00	10,24

Das Eigengewicht der Traverse ist in der Belastungstabelle berücksichtigt.
The dead load of the truss is considered in the load table.

BOX CORNER MIT 8 VERBINDERN BOX CORNER WITH 8 CONNECTORS CODE F24BOX



8 x
5,6 kg

HALBKONUS FÜR BOXCORNER HALFCONNECTOR FOR BOXCORNER CODE F24BOX-C



SPACER FEMALE 140MM CODE F24S140



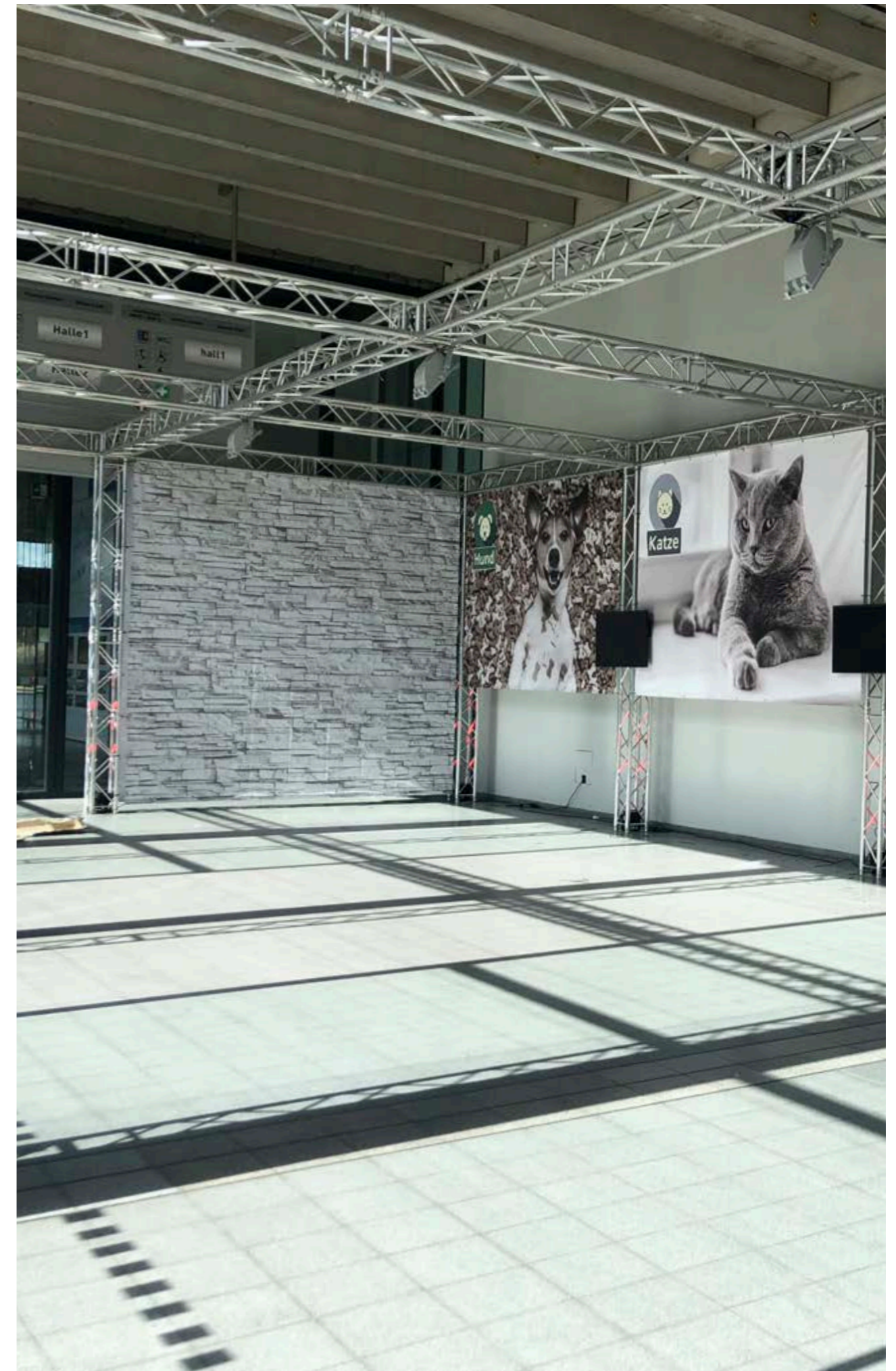
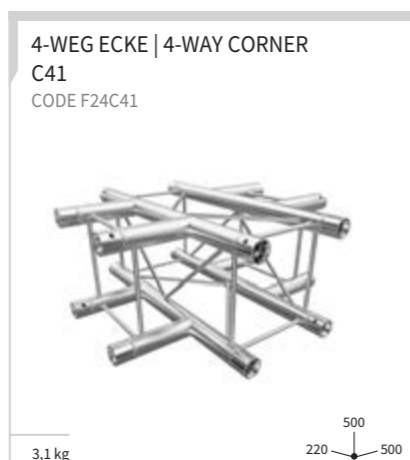
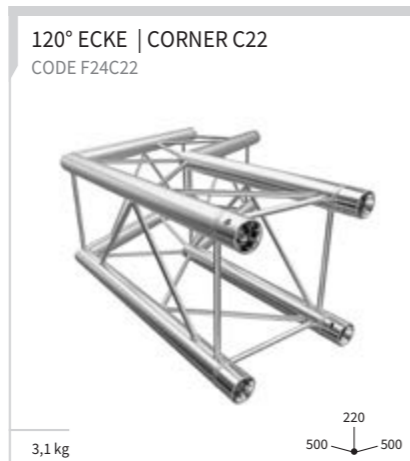

F31(PL)



Das F31(PL) Traversensystem von Global Truss ist ein 1-Punkt System und dient als flexibles Hilfsmittel für geringe Lasten. Es kann frei mit den anderen Systemen aus der F3x Serie kombiniert werden und wird meist im Messebau angewendet.

Das Gurtrohr besteht aus Aluminium 50 (48) x 2 (3) mm. Verbunden werden die Traversen mit konischen Verbindern, welche im Lieferumfang enthalten sind. Wie alle Global Truss Traversen lässt sich auch diese in beliebigen Farben pulverbeschichten.

The F31 (PL) truss series by Global Truss is a 1-point system and is used as flexible support for low loads. It can be used with other truss from the F3x system as needed and its main application is exhibition stands.

The 50 (48) x 2 (3) mm main tube is made of aluminium. The truss pieces are connected with the included conical

TECHNISCHE DATEN

Rohrdurchmesser Hauptrohr: F31 50mm / F31PL 48mm
 Wandstärke: 2mm F31 / 3mm F31PL
 Material: Al EN AW-6082 T6
 konische Verbinder im Lieferumfang enthalten

TECHNICAL DATA

Pipe diameter: F31 50mm / F31PL 48mm
 Wall thickness: 2mm F31 / 3mm F31PL
 Material: Al EN AW-6082 T6
 Connectors included



LOAD TABLE

Load for any point of the coupling

Span	Uniform distribution load	Deflection	Center point load	Deflection
m	kg / m	cm	kg	cm
0,50	912	0,1	228	0,1
1,00	227	0,5	113	0,4
1,50	100	1,1	75	0,9
2,00	55	1,9	55	1,6
2,50	28	2,5	44	2,5
3,00	15	3,0	29	3,0
3,50	9	3,5	20	3,5
4,00	5	4,0	14	4,0
4,50	3	4,5	10	4,5
5,00	2	5,0	7	5,0

Load without coupling

Span	Uniform distribution load	Deflection	Center point load	Deflection
m	kg / m	cm	kg	cm
0,50	2014	0,3	503	0,2
1,00	466	1,0	251	0,9
1,50	137	1,3	128	1,3
2,00	56	2,0	71	2,0
2,50	28	2,5	44	2,3
3,00	15	3,0	29	3,0

F31 STÜCKE | TUBES

CODE	Länge/length
F31025	25 cm
F31050	50 cm
F31100	100 cm
F31150	150 cm
F31200	200 cm
F31250	250 cm
F31300	300 cm

F31PL STÜCKE | TUBES

CODE	Länge/length
F31025PL	25 cm
F31050PL	50 cm
F31100PL	100 cm
F31150PL	150 cm
F31200PL	200 cm
F31250PL	250 cm
F31300PL	300 cm



F31 KREISSTÜCKE | CIRCLE PARTS

CODE	Ø Kreis/circle	Kreisstück/circle part
F31R050-180	1,0 m	1 Stück 180°
F31R075-90	1,5 m	1 Stück 90°
F31R100-90	2,0 m	1 Stück 90°
F31R125-90	2,5 m	1 Stück 90°

F31PL KREISSTÜCKE | CIRCLE PARTS

CODE	Ø Kreis/circle	Kreisstück/circle part
F31R050-180PL	1,0 m	1 Stück 180°
F31R075-90PL	1,5 m	1 Stück 90°
F31R100-90PL	2,0 m	1 Stück 90°
F31R125-90PL	2,5 m	1 Stück 90°



F31 ECKEN | CORNER

CODE	Description
F31C30	3-Wege Ecke corner
F31T35	3-Wege T-Stück joint
F31T40	4-Wege T-Stück joint
F31C41	4-Wege X-Stück joint
F31C55	5-Wege X-Stück joint



6-ECKWÜRFEL | CUBE

Gewinde M10
Lieferung inkl. konischer Stift und R-Clip.
delivery incl. conical connector and r-clip.

CODE ST5006-1 F31-F44
CODE ST5006-1B F31-F44 schwarz



SPEZIALECKE | CORNER 120°

Gewinde M12
Lieferung erfolgt ohne Konusverbinder
delivery without conical connectors, M12 thread

CODE 5-CUBE-120



SPEZIALECKE | CORNER 135°

Gewinde M12
Lieferung erfolgt ohne Konusverbinder
delivery without conical connectors, M12 thread

CODE 5-CUBE-135



INDOOR STANDFUSS | STAND PLATE

CODE 27360 F31

Maße: L 45,6 cm | B 36 cm | H 15,4 cm
Dimensions: L 45,6 cm | W 36 cm | H 15,4 cm



INDOOR STANDFUSS F31 RUND
INDOOR STAND PLATE F31 ROUND

CODE STR-031PL F31PL
CODE 27362 F31

Maße: Ø 43,5 cm | H 13 cm
Dimensions: Ø 43,5 cm | H 13 cm



KONUSVERBINDER | CONE

CODE F34BOXC Standard M10
CODE F34BOXD Standard M12
CODE F34BOXCPL PL-Version M10
CODE F34BOXDPL PL-Version M12



ANWENDUNGSBEISPIELE | EXAMPLE OF USE

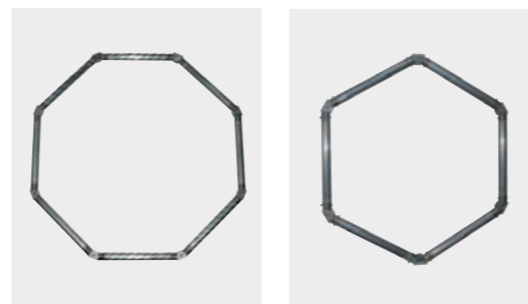

INDOOR STANDFUSS | STAND PLATE

Bestens geeignet für Werbepäsentationen aller Art. Nutzen Sie diesen flexiblen Rahmen z. B. für Ihren Banner, befestigen Sie eine Leinwand für Ihre Videopräsentation oder einfach als Trennwand.

Ideally suited for promotional presentations. Use this flexible framework for. As for your banner, attach a canvas for your video presentation, or simply as a partition.



U-TOP

U-FRAME

Mit U-Frame 50 und U-Top 50 hat Global Truss ab sofort eine äußerst flexible und komplett modulare Lösung für frei hängende Scheinwerfer im Angebot. Das in Leichtbauweise ausgeführte System erlaubt die theoretisch unendliche Konfiguration aus Einzel- und Doppelaufhängungen sowie Leitersystemen mit mehreren Scheinwerfern – sowohl hängend als auch stehend montiert.

Jede Kombination der beiden Module kann dabei eine Punktbelastung von max. 95 kg tragen. Durch die praktischen Sicherungsbefestigungen an jeder Seite des U-Frame können zudem vielfältige Scheinwerfertypen montiert werden. Für Leiterkonfigurationen können bis zu zehn U-Frame-50- /U-Top-50-Kombinationen untereinander angebracht werden, ohne dass weitere Rigging-Maßnahmen notwendig werden.

Die Aufhängung kann über die mitgelieferten Ringösen oder mit Swivelcouplern erfolgen. U-Frame 50 und U-Top 50 wurden von Global Truss bewusst für den schnellen und einfach zu handhabenden Einsatz hin entwickelt und lassen sich in unterschiedlichsten Veranstaltungsumgebungen einsetzen.

U-Frame 50 und U-Top 50 sind standardmäßig in silbernem und Stage Black Finish erhältlich. Weitere Farben können auf Anfrage umgesetzt werden.

With U-Frame and U-Top Global Truss offers now a highly flexible and completely modular solution for suspended lights. The lightweight system enables a theoretically infinite configuration of single and double suspension as well as ladder systems for various lights - both suspended and upright mounted.

A combination of the two modules can carry a point load of max. 48 kg. By the functional security fasteners of each side of the U-Frame diverse types of lights can be mounted. For ladder configurations up to 10 U-Frame / U-Top combinations can be mounted one below the other, without further rigging actions.

The suspension can be made by the supplied ring eyes or with swivel couplers.

U-Frame and U-Top were developed by Global Truss for quick and easy-to-use application in a variety of event environments.

U-Frame and U-Top are available as standard in silver and black. Other colors on request.

U-TOP 50

CODE UTOP50 / UTOP50-B



Maße: 600 x 110 x 50 mm (L/B/H)
 Gewicht: 1,5 kg
 Gewinde: M12
 Wandstärke: 3mm
 Material: ALMgSi F31
 konische Verbinder und Ringschraube M12: im Lieferumfang enthalten

Dimensions: 600 x 110 x 50 mm (W/D/H)
 Weight: 1,5 kg
 Thread: M12
 Wall thickness: 3mm
 Material: ALMgSi F31
 Connectors and eyebolt M12: included

U-TOP 100

CODE UTOP100 / UTOP100-B



Maße: 1100 x 110 x 50 mm (L/B/H)
 Gewicht: 2,4 kg
 Gewinde: M12
 Wandstärke: 3mm
 Material: ALMgSi F31
 konische Verbinder und Ringschraube M12: im Lieferumfang enthalten

Dimensions: 1100 x 110 x 50 mm (W/D/H)
 Weight: 2,4 kg
 Thread: M12
 Wall thickness: 3mm
 Material: ALMgSi F31
 Connectors and eyebolt M12: included

U-FRAME 50

CODE UFRAME50 / UFRAME50-B

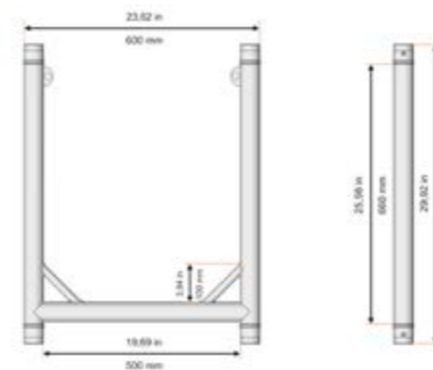

Maße: 600 x 760 x 50 mm (L/B/H)
 Gewicht: 3,9 kg
 Gewinde: M12
 Wandstärke: 3mm
 Material: ALMgSi F31
 konische Verbinder und Ringschraube M12: im Lieferumfang enthalten

Dimensions: 600 x 760 x 50 mm (W/D/H)
 Weight: 3,9 kg
 Thread: M12
 Wall thickness: 3mm
 Material: ALMgSi F31
 Connectors and eyebolt M12: included

U-FRAME 100

CODE UFRAME100 / UFRAME100-B

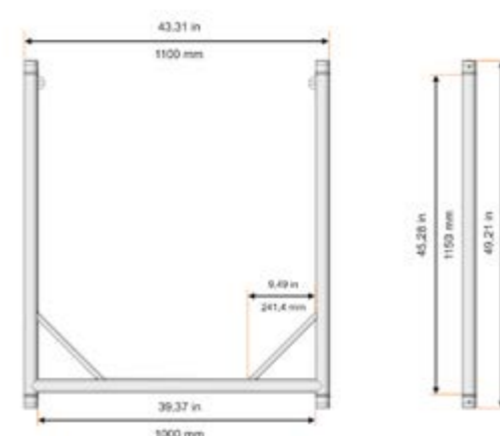

Maße: 1100 x 1250 x 50 mm (L/B/H)
 Gewicht: 5,9 kg
 Gewinde: M12
 Wandstärke: 3mm
 Material: ALMgSi F31
 konische Verbinder und Ringschraube M12: im Lieferumfang enthalten

Dimensions: 1100 x 1250 x 50 mm (W/D/H)
 Weight: 5,9 kg
 Thread: M12
 Wall thickness: 3mm
 Material: ALMgSi F31
 Connectors and eyebolt M12: included

F32

Das F32 Traversensystem von Global Truss ist ein TÜV-geprüftes 2-Punkt System mit einem Außenmaß von 29cm. Konstruktionen im Verbund als Rasterdecke (Grid) für Messestände und Festinstallationen lassen sich mit diesem System ideal realisieren. Kleine Auskragungen und Querstrecken mit geringer Belastung sind ebenso möglich. Im Gridverbund sind so Spannweiten bis 10m möglich.

Die F32 Traverse ist aus 50x2mm Gurtrohren und 20x2mm Diagonalbracings aus Aluminium gefertigt. Verbunden werden die Traversen mit konischen Verbindern, welche im Lieferumfang enthalten sind. Wie alle Global Truss Traversen lässt sich auch diese in beliebigen Farben pulverbeschichten.

The F32 truss series by Global Truss is a TÜV approved 2-point system with an external dimension of 29cm. Grid constructions for exhibition stands or permanent installations are possible with this system. Short outrigs or cross ways with little loads can also be created. As a grid a maximum span of up to 10 meters can be used.

The F32 truss is built with 50 x 2mm main tubes and 20 x 2mm diagonal braces of aluminium. The truss pieces are connected with the included conical connectors. This truss and all other Global Truss series can be powder coated in every RAL colour.



TECHNISCHE DATEN

Rohrdurchmesser Hauptrohr: 50 mm
 Wandstärke: 2,0 mm
 Material: Al EN AW-6082 T6
 Rohrdurchmesser Brace: 20 mm
 Konische Verbinder: enthalten

TECHNICAL DATA

Pipe diameter: 50 mm
 Wall thickness: 2,0 mm
 Material: Al EN AW-6082 T6
 Brace diameter: 20 mm
 Connectors: included



GERADEN | STRAIGHTS

CODE	Länge length	Gewicht weight
F32025	25 cm	1,3 kg
F32050	50 cm	1,7 kg
F32075	75 cm	2,0 kg
F32100	100 cm	2,5 kg
F32150	150 cm	3,5 kg
F32200	200 cm	4,6 kg
F32250	250 cm	5,7 kg
F32300	300 cm	6,7 kg
F32350	350 cm	7,8 kg
F32400	400 cm	8,6 kg
F32450	450 cm	9,9 kg
F32500	500 cm	10,9 kg



BODENPLATTE | BASE PLATE CODE F32BASE



1,0 kg
 60
 50 320

T-STÜCK | JOINT T35H CODE F32T35H



5,5 kg
 500
 50 500

T-STÜCK | JOINT T35V CODE F32T35V



5,5 kg
 290
 500 500

T-STÜCK | JOINT T42H CODE F32T42H



6,0 kg
 500
 500 500

T-STÜCK | JOINT T42V CODE F32T42V



6,0 kg
 500
 500 500

X-STÜCK | JOINT C41V CODE F32C41V



6,0 kg
 290
 500 500

LOAD TABLE

Span	Uniform distribution load		Center point load		point load in third-point	
	kg / m	Deflection cm	kg	Deflection cm	kg	Deflection cm
2,00	504,00	0,17	762,00	0,21	484,00	0,22
3,00	336,00	0,57	573,00	0,52	380,00	0,59
4,00	219,00	1,19	439,00	0,96	311,00	1,15
5,00	140,00	1,86	349,00	1,50	262,00	1,90
6,00	96,00	2,69	289,00	2,16	217,00	2,74
7,00	70,00	3,66	245,00	2,95	184,00	3,74
8,00	53,00	4,79	213,00	3,87	159,00	4,89
9,00	42,00	6,06	187,00	4,92	140,00	6,19
10,00	33,00	7,50	166,00	6,10	125,00	7,65

Span	kg / m	Deflection cm	kg	Deflection cm	kg	Deflection cm
2,00	504,00	0,17	589,00	0,16	442,00	0,20
3,00	261,00	0,45	391,00	0,36	293,00	0,46
4,00	146,00	0,80	291,00	0,64	218,00	0,81
5,00	92,00	1,24	231,00	1,00	173,00	1,27
6,00	63,00	1,79	190,00	1,45	143,00	1,83
7,00	46,00	2,45	161,00	1,98	121,00	2,50
8,00	35,00	3,20	139,00	2,60	104,00	3,27
9,00	27,00	4,06	121,00	3,31	91,00	4,14
10,00	21,00	5,02	107,00	4,12	80,00	5,12

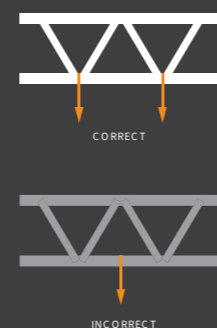

(*) values only valid if the load burdens the junction

Compression chord held every 1.0m!

Das Eigengewicht der Traverse ist in der Belastungstabelle berücksichtigt.
 The dead load of the truss is considered in the load table.

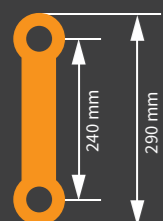

X-STÜCK | JOINT C41H
CODE F32C41H



6,0 kg 50 500 500

45° ECKE | CORNER C19H
CODE F32C19H



7,0 kg 50 1000 1000

45° ECKE | CORNER C19V
CODE F32C19V



7,0 kg 290 500 500

KREISSTÜCKE | CIRCLE PARTS - HORIZONTAL

CODE	Ø Kreis/circle	Kreisstück/circle part	Gewicht/weight
F32R10-180H	2,0 m	1 Stück 180°	6,9 kg
F32R15-90H	3,0 m	1 Stück 90°	5,3 kg
F32R20-90H	4,0 m	1 Stück 90°	6,9 kg
F32R25-45H	5,0 m	1 Stück 45°	4,6 kg
F32R30-45H	6,0 m	1 Stück 45°	5,2 kg
F32R35-45H	7,0 m	1 Stück 45°	6,2 kg
F32R40-45H	8,0 m	1 Stück 45°	6,2 kg

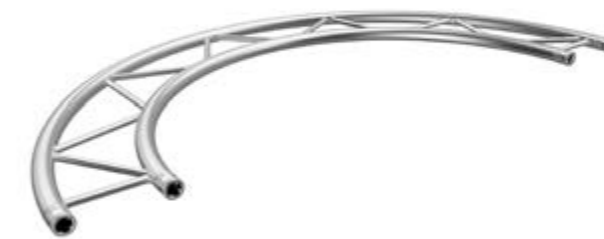

60° ECKE | CORNER C20H
CODE F32C20H



7,0 kg 50 1000 1000

60° ECKE | CORNER C20V
CODE F32C20V



7,0 kg 290 500 500

90° ECKE | CORNER C21H
CODE F32C21H



4,0 kg 50 500 500

KREISSTÜCKE | CIRCLE PARTS - VERTIKAL

CODE	Ø Kreis/circle	Kreisstück/circle part	Gewicht/weight
F32R10-180V	2,0 m	1 Stück 180°	6,9 kg
F32R15-90V	3,0 m	1 Stück 90°	5,3 kg
F32R20-90V	4,0 m	1 Stück 90°	6,9 kg
F32R25-45V	5,0 m	1 Stück 45°	4,6 kg
F32R30-45V	6,0 m	1 Stück 45°	5,2 kg
F32R35-45V	7,0 m	1 Stück 45°	6,2 kg
F32R40-45V	8,0 m	1 Stück 45°	6,2 kg



90° ECKE | CORNER C21V
CODE F32C21V



4,0 kg 290 500 500

120° ECKE | CORNER C22H
CODE F32C22H



4,0 kg 50 500 500

120° ECKE | CORNER C22V
CODE F32C22V



4,0 kg 290 500 500

3-WEG ECKE | 3-WAY CORNER C31V
CODE F32C31V



6,0 kg 500 500 500

ADAPTER F34 | F32
M12 Gewinde, M12 Thread
CODE F34ADAPTER

Halbkonus | Half connector
Seite | page 152



8 x 1,5 kg 290 50 290

TOP F32
Sonderteil für Bühnendächer
Special part for stage roof
CODE F32ROOF



1,5 kg 290 50 500

135° ECKE | CORNER C23H
CODE F32C23H



4,0 kg 50 500 500

135° ECKE | CORNER C23V
CODE F32C23V



4,0 kg 290 500 500

3-WEG ECKE | 3-WAY CORNER C31H
CODE F32C31H



6,0 kg 500 500 500

Zubehör/Accessories

VERBINDER SET
CONNECTOR SET
Konus, Bolzen & R-Clip
cone, pin and r-clip.
CODE 5002



ADAPTERKONUS
CONICAL ADAPTER
Konus F32 auf F34
cone F32 to F34
CODE F3432L links/left
CODE F3432R rechts/right



BOLZEN & R-CLIP
PIN & R-CLIP
CODE 5004



BOLZEN | PIN
Bolzen mit M8 Gewinde
pin with M8 thread
CODE 5005



F32-B

Das F32 Traversensystem von Global Truss ist ein TÜV-geprüftes 2-Punkt System mit einem Außenmaß von 29cm. Konstruktionen im Verbund als Rasterdecke (Grid) für Messestände und Festinstallationen lassen sich mit diesem System ideal realisieren. Kleine Auskragungen und Querstrecken mit geringer Belastung sind ebenso möglich. Im Gridverbund sind so Spannweiten bis 10m möglich.

Die F32 Traverse ist aus 50x2mm Gurtrohren und 20x2mm Diagonalbracings aus Aluminium gefertigt. Verbunden werden die Traversen mit konischen Verbindern, welche im Lieferumfang enthalten sind.

The F32 truss series by Global Truss is a TÜV approved 2-point system with an external dimension of 29cm. Grid constructions for exhibition stands or permanent installations are possible with this system. Short outrigs or cross ways with little loads can also be created. As a grid a maximum span of up to 10 meters can be used.

The F32 truss is built with 50 x 2mm main tubes and 20 x 2mm diagonal braces of aluminium. The truss pieces are connected with the included conical connectors.

TECHNISCHE DATEN

Rohrdurchmesser Hauptrohr: 50 mm
 Wandstärke: 2,0 mm
 Material: Al EN AW-6082 T6
 Rohrdurchmesser Brace: 20 mm
 Konische Verbinder: enthalten

TECHNICAL DATA

Pipe diameter: 50 mm
 Wall thickness: 2,0 mm
 Material: Al EN AW-6082 T6
 Brace diameter: 20 mm
 Connectors: included

GERADEN | STRAIGHTS

CODE	Länge length	Gewicht weight
F32025-B	25 cm	1,3 kg
F32050-B	50 cm	1,7 kg
F32100-B	100 cm	2,5 kg
F32150-B	150 cm	3,5 kg
F32200-B	200 cm	4,6 kg
F32250-B	250 cm	5,7 kg
F32300-B	300 cm	6,7 kg



BODENPLATTE | BASE PLATE CODE F32BASE-B



1,0 kg 60
50 320



LOAD TABLE

Span	Uniform distribution load		Center point load		point load in third-point	
	kg / m	Deflection cm	kg	Deflection cm	kg	Deflection cm
2,00	504,00	0,17	762,00	0,21	484,00	0,22
3,00	336,00	0,57	573,00	0,52	380,00	0,59
4,00	219,00	1,19	439,00	0,96	311,00	1,15
5,00	140,00	1,86	349,00	1,50	262,00	1,90
6,00	96,00	2,69	289,00	2,16	217,00	2,74
7,00	70,00	3,66	245,00	2,95	184,00	3,74
8,00	53,00	4,79	213,00	3,87	159,00	4,89
9,00	42,00	6,06	187,00	4,92	140,00	6,19
10,00	33,00	7,50	166,00	6,10	125,00	7,65

Span	kg / m	cm	kg	cm	kg	cm
2,00	504,00	0,17	589,00	0,16	442,00	0,20
3,00	261,00	0,45	391,00	0,36	293,00	0,46
4,00	146,00	0,80	291,00	0,64	218,00	0,81
5,00	92,00	1,24	231,00	1,00	173,00	1,27
6,00	63,00	1,79	190,00	1,45	143,00	1,83
7,00	46,00	2,45	161,00	1,98	121,00	2,50
8,00	35,00	3,20	139,00	2,60	104,00	3,27
9,00	27,00	4,06	121,00	3,31	91,00	4,14
10,00	21,00	5,02	107,00	4,12	80,00	5,12

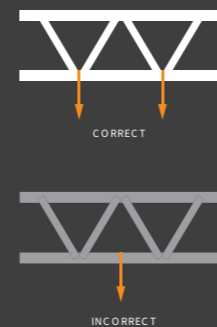

(*) values only valid if the load burdens the junction

Compression chord held every 1.0m!

Das Eigengewicht der Traverse ist in der Belastungstabelle berücksichtigt.
 The dead load of the truss is considered in the load table.

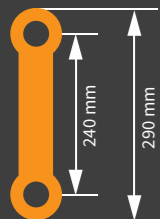



F33



Das F33 Traversensystem von Global Truss ist ein TÜV-geprüftes 3-Punkt System mit einem Außenmaß von 29cm. Auf Grund der Form bietet es innerhalb der F3x Serie das Beste Verhältnis von Transportvolumen zu Tragfähigkeit. Mit den Traversen der F33 Serie lassen sich Messestände und Bannerrahmen ideal umsetzen. Zudem werden sie auch gerne für Festinstallationen verwendet. Ausgelegt ist dieses System für eine Spannweite bis zu 18m.

Die F33 Traverse ist aus 50x2mm Gurtrohren und 20x2mm Diagonalbracings aus Aluminium gefertigt. Verbunden werden die Traversen mit konischen Verbindern, welche im Lieferumfang enthalten sind. Wie alle Global Truss Traversen lässt sich auch diese in beliebigen Farben pulverbeschichten.

The F33 truss series by Global Truss is a TÜV approved 3-point system with an external dimension of 29cm. Due to its shape it offers the best ratio between transportation volume and load capacity from the F3x range. Exhibition stands and banner frames can be created perfectly with truss pieces from the F33 system. Furthermore the system can be used for permanent installations or similar. The system offers a maximum span of up to 18 meters.

The F33 truss is built with 50 x 2mm main tubes and 20 x 2mm diagonal braces of aluminium. The truss pieces are connected with the included conical connectors. This truss and all other Global Truss series can be powder coated in every RAL colour.



GERADEN | STRAIGHTS F33

CODE	Länge length	Gewicht weight
F33017	17 cm	1,9 kg
F33018	18 cm	2,0 kg
F33019	19 cm	2,1 kg
F33020	20 cm	2,2 kg
F33021	21 cm	2,3 kg
F33022	22 cm	2,4 kg
F33023	23 cm	2,5 kg
F33024	24 cm	2,6 kg
F33025	25 cm	2,7 kg
F33040	40 cm	3,1 kg
F33050	50 cm	3,5 kg
F33055	55 cm	3,8 kg
F33060	60 cm	4,3 kg
F33065	65 cm	4,8 kg
F33070	70 cm	5,1 kg
F33075	75 cm	5,4 kg
F33100	100 cm	5,8 kg
F33150	150 cm	7,5 kg
F33200	200 cm	9,3 kg
F33250	250 cm	11,0 kg
F33300	300 cm	12,7 kg
F33350	350 cm	14,5 kg
F33400	400 cm	16,2 kg
F33450	450 cm	17,0 kg
F33500	500 cm	18,3 kg



TECHNISCHE DATEN

Rohrdurchmesser Hauptrohr:	50 mm
Wandstärke:	2,0 mm
Material:	Al EN AW-6082 T6
Rohrdurchmesser Brace:	20 mm
Konische Verbinder	enthalten

TECHNICAL DATA

Pipe diameter:	50 mm
Wall thickness:	2,0 mm
Material:	Al EN AW-6082 T6
Brace diameter:	20 mm
Connectors	included

KREISSTÜCKE | CIRCLE PARTS

CODE	Ø Kreis/circle	Kreisstück/circle part	Gewicht/weight
F33R10-90	2,0 m	1 Stück 90°	8,0 kg
F33R15-90	3,0 m	1 Stück 90°	10,5 kg
F33R20-90	4,0 m	1 Stück 90°	13,0 kg
F33R25-45	5,0 m	1 Stück 45°	10,0 kg
F33R30-45	6,0 m	1 Stück 45°	10,2 kg
F33R35-45	7,0 m	1 Stück 45°	11,8 kg
F33R40-45	8,0 m	1 Stück 45°	13,0 kg
F33R45-45	9,0 m	1 Stück 45°	14,5 kg
F33R50-30	10,0 m	1 Stück 30°	11,4 kg

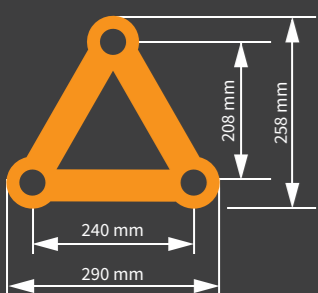

LOAD TABLE

Span	Uniform distribution load		Center point load		Point load in third-point		Point load in quarter-point		Point load in fifth-point	
	kg / m	Deflection cm	kg	Deflection cm	kg	Deflection cm	kg	Deflection cm	kg	Deflection cm
4	238	1,29	438	0,95	312	1,15	230	1,18	184	1,21
5	152	2,03	354	1,53	255	1,86	184	1,88	149	1,93
6	105	2,94	296	2,24	215	2,74	153	2,73	124	2,82
7	76	4,02	253	3,10	184	3,80	130	3,74	106	3,88
8	57	5,27	219	4,11	161	5,04	112	4,92	92	5,11
9	45	6,69	192	5,27	142	6,45	98	6,27	81	6,53
10	35	8,29	170	6,58	126	8,06	87	7,79	71	8,11
11	29	10,06	151	8,06	113	9,85	77	9,48	64	9,89
12	23	12,01	136	9,72	101	11,84	69	11,35	57	11,84
13	19	14,14	122	11,55	91	14,02	62	13,40	51	13,98
14	16	16,45	109	13,57	83	16,41	56	15,63	46	16,32
15	14	18,95	99	15,78	75	19,02	50	18,06	42	18,85
16	11	21,64	89	18,20	68	21,84	45	20,68	38	21,57
17	10	24,52	80	20,84	61	24,88	40	23,49	34	24,51
18	8	27,60	72	23,71	55	28,02	36	26,52	30	27,65

Das Eigengewicht der Traverse ist in der Belastungstabelle berücksichtigt.
The dead load of the truss is considered in the load table.

BODENPLATTE | BASE PLATE

CODE F33BASE



1,2 kg

45° ECKE | CORNER C19

CODE F33C19



7,2 kg

60° ECKE | CORNER C20

CODE F33C20



7,2 kg

90° ECKE | CORNER C21
CODE F33C21

5,7 kg

260
500 500

120° ECKE | CORNER C22
CODE F33C22

5,7 kg

260
500 500

135° ECKE | CORNER C23
CODE F33C23

5,7 kg

260
500 500

5-WEG ECKE | 5-WAY CORNER
C51
CODE F33C51

11,5 kg

500
500 500

5-WEG ECKE | 5-WAY CORNER
C52
CODE F33C52

11,5 kg

500
500 500

5-WEG ECKE | 5-WAY CORNER
C53
CODE F33C53

11,5 kg

500
500 500

90° ECKE | CORNER C24
CODE F33C24

5,7 kg

290
500 500

90° ECKE | CORNER C25
CODE F33C25

5,7 kg

290
500 500

3-WEG ECKE | 3-WAY CORNER
C31
CODE F33C31

8,4 kg

500
500 500

6-WEG ECKE | 6-WAY CORNER
C61
CODE F33C61

16,5 kg

500
500 500

T-STÜCK | JOINT T35
CODE F33T35

8,4 kg

290
500 500

T-STÜCK | JOINT T36
CODE F33T36

8,4 kg

260
500 500

3-WEG ECKE | 3-WAY CORNER
C32
CODE F33C32

8,4 kg

500
500 500

3-WEG ECKE | 3-WAY CORNER
C33
CODE F33C33

8,4 kg

500
500 500

3-WEG ECKE | 3-WAY CORNER
C34
CODE F33C34

8,4 kg

500
500 500

T-STÜCK | JOINT T37
CODE F33T37

8,4 kg

290
500 500

T-STÜCK | JOINT T38
CODE F33T38

8,4 kg

290
500 500

T-STÜCK | JOINT T39
CODE F33T39

8,4 kg

290
500 500

X-STÜCK | JOINT C41
CODE F33C41

9,3 kg

260
500 500

90° ECKE | CORNER C44
CODE F33C44

11,5 kg

500
500 500

90° ECKE | CORNER C45
CODE F33C45

11,5 kg

500
500 500

T-STÜCK | JOINT T42
CODE F33T42

11,5 kg

290
500 500

T-STÜCK | JOINT T43
CODE F33T43

11,5 kg

290
500 500

SPINDEL | SPINDLE
CODE F33SPINDELHöhe von 35 - 70 cm verstellbar
Height from 35 - 70 cm adjustable

7,0 kg

550
290 ← 290

WANDHALTER|WALLBRACKET F33/F34

CODE 115641 Silber / silver
CODE 115642 Schwarz / black

Coupler = Code 823

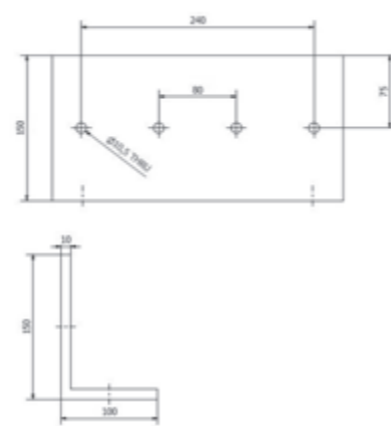

PULVERBESCHICHTUNG | POWDER COATING

Wir bieten bereits die meisten unserer Systeme auch als schwarze Version mit Stage Black Pulverbeschichtung an. Diese sind natürlich bereits ab Lager lieferbar. Wenn Du dennoch mal eine Traverse in einer anderen Farbe benötigst können wir auch Dies innerhalb kürzester Zeit umsetzen. Unser Partner für Pulverbeschichtung färbt Deine Wunschtraverse (bis max. 500 cm) in jedem verfügbaren RAL Wert. Das ist zum Beispiel äußerst praktisch bei Cooperate Events oder ähnlichem wo der Farbton dem CI des Kunden entsprechen soll. Sprech uns einfach an. Wir freuen uns Dir weiter zu helfen.

We already offer most of our systems as a Black version with Stage Black powder coating. These are of course available directly from stock. If you need a truss in a different color, we can also realize this within a short time. Our powder coating partner will color your truss pieces (up to a maximum of 500 cm) in any available RAL code. This is very useful at cooperate events or similar where the color tone has to match the customer's CI. Just contact us. We look forward to helping you further.



F33-B



Das F33 Traversensystem von Global Truss ist ein TÜV-geprüftes 3-Punkt System mit einem Außenmaß von 29cm. Auf Grund der Form bietet es innerhalb der F3x Serie das Beste Verhältnis von Transportvolumen zu Tragfähigkeit. Mit den Traversen der F33 Serie lassen sich Messestände und Bannerrahmen ideal umsetzen. Zudem werden sie auch gerne für Festinstallationen verwendet. Ausgelegt ist dieses System für eine Spannweite bis zu 18m.

Die F33 Traverse ist aus 50x2mm Gurtrohren und 20x2mm Diagonalbracings aus Aluminium gefertigt. Verbunden werden die Traversen mit konischen Verbindern, welche im Lieferumfang enthalten sind.

The F33 truss series by Global Truss is a TÜV approved 3-point system with an external dimension of 29cm. Due to its shape it offers the best ratio between transportation volume and load capacity from the F3x range. Exhibition stands and banner frames can be created perfectly with truss pieces from the F33 system. Furthermore the system can be used for permanent installations or similar. The system offers a maximum span of up to 18 meters.

The F33 truss is built with 50 x 2mm main tubes and 20 x 2mm diagonal braces of aluminium. The truss pieces are connected with the included conical connectors.



GERADEN | STRAIGHTS F33

CODE	Länge length	Gewicht weight
F33050	50 cm	3,5 kg
F33100	100 cm	5,8 kg
F33150	150 cm	7,5 kg
F33200	200 cm	9,3 kg
F33250	250 cm	11,0 kg
F33300	300 cm	12,7 kg



BODENPLATTE | BASE PLATE

CODE F33BASE



1,2 kg 50 320 320

TECHNISCHE DATEN

Rohrdurchmesser Hauptrohr: 50 mm
 Wandstärke: 2,0 mm
 Material: Al EN AW-6082 T6
 Rohrdurchmesser Brace: 20 mm
 Konische Verbinder: enthalten

TECHNICAL DATA

Pipe diameter: 50 mm
 Wall thickness: 2,0 mm
 Material: Al EN AW-6082 T6
 Brace diameter: 20 mm
 Connectors: included

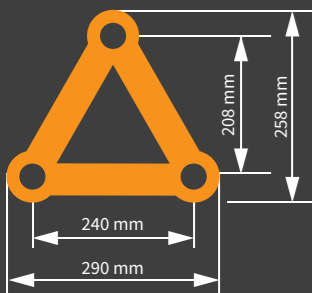

LOAD TABLE

Span	Uniform distribution load		Center point load		Point load in third-point		Point load in quarter-point		Point load in fifth-point	
	kg / m	Deflection	kg	Deflection	kg	Deflection	kg	Deflection	kg	Deflection
4	238	1,29	438	0,95	312	1,15	230	1,18	184	1,21
5	152	2,03	354	1,53	255	1,86	184	1,88	149	1,93
6	105	2,94	296	2,24	215	2,74	153	2,73	124	2,82
7	76	4,02	253	3,10	184	3,80	130	3,74	106	3,88
8	57	5,27	219	4,11	161	5,04	112	4,92	92	5,11
9	45	6,69	192	5,27	142	6,45	98	6,27	81	6,53
10	35	8,29	170	6,58	126	8,06	87	7,79	71	8,11
11	29	10,06	151	8,06	113	9,85	77	9,48	64	9,89
12	23	12,01	136	9,72	101	11,84	69	11,35	57	11,84
13	19	14,14	122	11,55	91	14,02	62	13,40	51	13,98
14	16	16,45	109	13,57	83	16,41	56	15,63	46	16,32
15	14	18,95	99	15,78	75	19,02	50	18,06	42	18,85
16	11	21,64	89	18,20	68	21,84	45	20,68	38	21,57
17	10	24,52	80	20,84	61	24,88	40	23,49	34	24,51
18	8	27,60	72	23,71	55	28,02	36	26,52	30	27,65

Das Eigengewicht der Traverse ist in der Belastungstabelle berücksichtigt.
 The dead load of the truss is considered in the load table.



F33PL



Das F33PL Traversensystem von Global Truss ist ein TÜV-geprüftes 3-Punkt System mit einem Außenmaß von 29cm. Auf Grund der Form bietet es innerhalb der F3x Serie ein sehr gutes Verhältnis von Transportvolumen zu Tragfähigkeit. Mit den Traversen der F33PL Serie lassen sich Messestände und Bannerrahmen ideal umsetzen. Zudem werden sie auch gerne für Festinstallationen verwendet. Ausgelegt ist dieses System für eine Spannweite bis zu 18m.

Die F33PL Traverse ist aus 50x2mm Gurtrohren und 16x2mm Diagonalbracings aus Aluminium gefertigt. Verbunden werden die Traversen mit konischen Verbindern, welche im Lieferumfang enthalten sind. Wie alle Global Truss Traversen lässt sich auch diese in beliebigen Farben pulverbeschichten.

The F33PL truss series by Global Truss is a TÜV approved 3-point system with an external dimension of 29cm. Due to its shape it offers a great ratio between transportation volume and load capacity from the F3x range. Exhibition stands and banner frames can be created perfectly with truss pieces from the F33PL system. Furthermore the system can be used for permanent installations or similar. The system offers a maximum span of up to 18 meters.

The F33PL truss is built with 50 x 2mm main tubes and 16 x 2mm diagonal braces of aluminium. The truss pieces are connected with the included conical connectors. This truss and all other Global Truss series can be powder coated in every RAL colour.

GERADEN | STRAIGHTS

CODE	Länge length	CODE	Länge length
F33017PL	17 cm	F33065PL	65 cm
F33018PL	18 cm	F33070PL	70 cm
F33019PL	19 cm	F33075PL	75 cm
F33020PL	20 cm	F33100PL	100 cm
F33021PL	21 cm	F33150PL	150 cm
F33022PL	22 cm	F33200PL	200 cm
F33023PL	23 cm	F33250PL	250 cm
F33024PL	24 cm	F33300PL	300 cm
F33025PL	25 cm	F33350PL	350 cm
F33050PL	50 cm	F33400PL	400 cm
F33055PL	55 cm	F33450PL	450 cm
F33060PL	60 cm	F33500PL	500 cm



TECHNISCHE DATEN

Rohrdurchmesser Hauptrohr:	50 mm
Wandstärke:	2,0 mm
Material:	Al EN AW-6082 T6
Rohrdurchmesser Brace:	16 x 2 mm
Konische Verbinder	enthalten

TECHNICAL DATA

Pipe diameter:	50 mm
Wall thickness:	2,0 mm
Material:	Al EN AW-6082 T6
Brace diameter:	16 x 2 mm
Connectors	included



KREISSTÜCKE | CIRCLE PARTS

CODE	Ø Kreis circle	Kreisstück circle part	Gewicht weight
F33R10-90PL	2,0 m	1 Stück 90°	8,0 kg
F33R15-90PL	3,0 m	1 Stück 90°	10,5 kg
F33R20-90PL	4,0 m	1 Stück 90°	13,0 kg
F33R25-45PL	5,0 m	1 Stück 45°	10,0 kg
F33R30-45PL	6,0 m	1 Stück 45°	10,2 kg
F33R35-45PL	7,0 m	1 Stück 45°	11,8 kg
F33R40-45PL	8,0 m	1 Stück 45°	13,0 kg
F33R45-45PL	9,0 m	1 Stück 45°	14,5 kg
F33R50-30PL	10,0 m	1 Stück 30°	11,4 kg



LOAD TABLE

Span	Uniform distribution load		Center point load		Point load in third-point		Point load in quarter-point		Point load in fifth-point	
	kg / m	Deflection	kg	Deflection	kg	Deflection	kg	Deflection	kg	Deflection
4,00	246,00	1,30	461,00	0,98	333,00	1,20	238,00	1,20	193,00	1,24
5,00	156,00	2,04	371,00	1,56	270,00	1,93	191,00	1,90	155,00	1,97
6,00	108,00	2,95	308,00	2,28	226,00	2,82	158,00	2,75	129,00	2,86
7,00	78,00	4,03	263,00	3,15	193,00	3,89	134,00	3,77	110,00	3,93
8,00	59,00	5,28	227,00	4,16	168,00	5,14	116,00	4,95	95,00	5,17
9,00	46,00	6,70	199,00	5,32	148,00	6,57	101,00	6,30	84,00	6,59
10,00	36,00	8,29	176,00	6,64	131,00	8,18	89,00	7,82	74,00	8,18
11,00	29,00	10,05	157,00	8,12	117,00	9,98	80,00	9,51	66,00	9,96
12,00	24,00	12,00	140,00	9,77	105,00	11,98	71,00	11,38	59,00	11,91
13,00	20,00	14,12	126,00	11,60	95,00	14,17	64,00	13,42	53,00	14,06
14,00	17,00	16,43	113,00	13,62	86,00	16,57	57,00	15,65	48,00	16,39
15,00	14,00	18,92	102,00	15,83	78,00	19,18	52,00	18,07	43,00	18,92
16,00	12,00	21,60	92,00	18,24	70,00	21,97	46,00	20,68	39,00	21,65
17,00	10,00	24,48	83,00	20,86	63,00	24,87	42,00	23,49	35,00	24,58
18,00	8,00	27,55	75,00	23,71	57,00	27,96	38,00	26,51	32,00	27,71

Das Eigengewicht der Traverse ist in der Belastungstabelle berücksichtigt.
The dead load of the truss is considered in the load table.

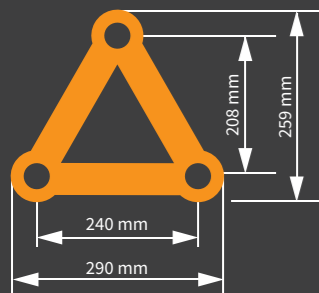

BODENPLATTE | BASE PLATE PL

CODE F33BASEPL



1,0 kg

45° ECKE | CORNER C19 PL

CODE F33C19PL



7,2 kg

60° ECKE | CORNER C20 PL

CODE F33C20PL



7,2 kg

90° ECKE | CORNER C21 PL
CODE F33C21PL

5,7 kg

260
500 500

120° ECKE | CORNER C22 PL
CODE F33C22PL

5,7 kg

260
500 500

135° ECKE | CORNER C23 PL
CODE F33C23PL

5,7 kg

260
500 500

5-WEG ECKE | 5-WAY CORNER C51 PL
CODE F33C51PL

11,4 kg

500
500 500

5-WEG ECKE | 5-WAY CORNER C52 PL
CODE F33C52PL

11,4 kg

500
500 500

5-WEG ECKE | 5-WAY CORNER C53 PL
CODE F33C53PL

11,4 kg

500
500 500

90° ECKE C24 PL
CODE F33C24PL

5,7 kg

290
500 500

90° ECKE | CORNER C25 PL
CODE F33C25PL

5,7 kg

290
500 500

3-WEG ECKE | 3-WAY CORNER C31 PL
CODE F33C31PL

8,4 kg

500
500 500

6-WEG ECKE | 6-WAY CORNER C61 PL
CODE F33C61PL

13,0 kg

500
500 500

T-STÜCK | JOINT T35 PL
CODE F33T35PL

8,4 kg

290
500 500

T-STÜCK | JOINT T36 PL
CODE F33T36PL

8,4 kg

290
500 500

3-WEG ECKE | 3-WAY CORNER C32 PL
CODE F33C32PL

8,4 kg

500
500 500

3-WEG ECKE | 3-WAY CORNER C33 PL
CODE F33C33PL

8,4 kg

500
500 500

3-WEG ECKE | 3-WAY CORNER C34 PL
CODE F33C34PL

8,4 kg

500
500 500

T-STÜCK | JOINT T37 PL
CODE F33T37PL

8,4 kg

290
500 500

T-STÜCK | JOINT T38 PL
CODE F33T38PL

8,4 kg

290
500 500

T-STÜCK | JOINT T39 PL
CODE F33T39PL

8,4 kg

290
500 500

X-STÜCK | JOINT C41 PL
CODE F33C41PL

9,3 kg

260
500 500

4-WEG ECKE | 4-WAY CORNER C44 PL
CODE F33C44PL

10,0 kg

500
500 500

4-WEG ECKE | 4-WAY CORNER C45 PL
CODE F33C45PL

10,0 kg

500
500 500

T-STÜCK | JOINT T42 PL
CODE F33T42PL

8,4 kg

500
500 500

T-STÜCK | JOINT T43 PL
CODE F33T43PL

8,4 kg

500
500 500

WANDHALTER | WALLBRACKET F33/F34
CODE 115641 Silber / silver
CODE 115642 Schwarz / black
Maße | Dimensions 150 x 100 x 300 mm

F33PL-B



Das F33PL Traversensystem von Global Truss ist ein TÜV-geprüftes 3-Punkt System mit einem Außenmaß von 29cm. Auf Grund der Form bietet es innerhalb der F3x Serie ein sehr gutes Verhältnis von Transportvolumen zu Tragfähigkeit. Mit den Traversen der F33PL Serie lassen sich Messestände und Bannerrahmen ideal umsetzen. Zudem werden sie auch gerne für Festinstallationen verwendet. Ausgelegt ist dieses System für eine Spannweite bis zu 18m.

Die F33PL Traverse ist aus 50x2mm Gurtrohren und 16x2mm Diagonalbracings aus Aluminium gefertigt. Verbunden werden die Traversen mit konischen Verbindern, welche im Lieferumfang enthalten sind.

The F33PL truss series by Global Truss is a TÜV approved 3-point system with an external dimension of 29cm. Due to its shape it offers a great ratio between transportation volume and load capacity from the F3x range. Exhibition stands and banner frames can be created perfectly with truss pieces from the F33PL system. Furthermore the system can be used for permanent installations or similar. The system offers a maximum span of up to 18 meters.

The F33PL truss is built with 50 x 2mm main tubes and 16 x 2mm diagonal braces of aluminium. The truss pieces are connected with the included conical connectors.

TECHNISCHE DATEN

Rohrdurchmesser Hauptrohr: 50 mm
 Wandstärke: 2,0 mm
 Material: Al EN AW-6082 T6
 Rohrdurchmesser Brace: 16 x 2 mm
 Konische Verbinder: enthalten

TECHNICAL DATA

Pipe diameter: 50 mm
 Wall thickness: 2,0 mm
 Material: Al EN AW-6082 T6
 Brace diameter: 16 x 2 mm
 Connectors: included



LOAD TABLE

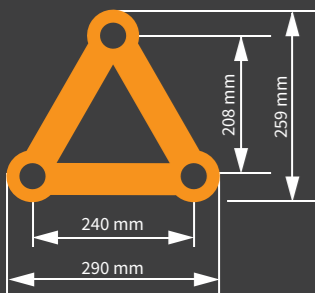

Span	Uniform distribution load		Center point load		Point load in third-point		Point load in quarter-point		Point load in fifth-point	
	kg / m	Deflection cm	kg	Deflection cm	kg	Deflection cm	kg	Deflection cm	kg	Deflection cm
4,00	246,00	1,30	461,00	0,98	333,00	1,20	238,00	1,20	193,00	1,24
5,00	156,00	2,04	371,00	1,56	270,00	1,93	191,00	1,90	155,00	1,97
6,00	108,00	2,95	308,00	2,28	226,00	2,82	158,00	2,75	129,00	2,86
7,00	78,00	4,03	263,00	3,15	193,00	3,89	134,00	3,77	110,00	3,93
8,00	59,00	5,28	227,00	4,16	168,00	5,14	116,00	4,95	95,00	5,17
9,00	46,00	6,70	199,00	5,32	148,00	6,57	101,00	6,30	84,00	6,59
10,00	36,00	8,29	176,00	6,64	131,00	8,18	89,00	7,82	74,00	8,18
11,00	29,00	10,05	157,00	8,12	117,00	9,98	80,00	9,51	66,00	9,96
12,00	24,00	12,00	140,00	9,77	105,00	11,98	71,00	11,38	59,00	11,91
13,00	20,00	14,12	126,00	11,60	95,00	14,17	64,00	13,42	53,00	14,06
14,00	17,00	16,43	113,00	13,62	86,00	16,57	57,00	15,65	48,00	16,39
15,00	14,00	18,92	102,00	15,83	78,00	19,18	52,00	18,07	43,00	18,92
16,00	12,00	21,60	92,00	18,24	70,00	21,97	46,00	20,68	39,00	21,65
17,00	10,00	24,48	83,00	20,86	63,00	24,87	42,00	23,49	35,00	24,58
18,00	8,00	27,55	75,00	23,71	57,00	27,96	38,00	26,51	32,00	27,71

Das Eigengewicht der Traverse ist in der Belastungstabelle berücksichtigt.
 The dead load of the truss is considered in the load table.

BODENPLATTE | BASE PLATE PL
 CODE F33BASEPL-B



1,0 kg
 50
 320 320

GERADEN | STRAIGHTS

CODE	Länge length
F33021PL-B	21 cm
F33025PL-B	25 cm
F33050PL-B	50 cm
F33100PL-B	100 cm
F33200PL-B	200 cm
F33300PL-B	300 cm



90° ECKE | CORNER C21 PL
 CODE F33C21PL-B



5,7 kg
 260
 500 500

90° ECKE | CORNER C24 PL
 CODE F33C24PL-B



5,7 kg
 290
 500 500

90° ECKE | CORNER C25 PL
 CODE F33C25PL-B



5,7 kg
 290
 500 500

3-WEG ECKE | 3-WAY CORNER C31 PL
 CODE F33C31PL-B



8,4 kg
 500
 500 500

3-WEG ECKE | 3-WAY CORNER C32 PL
 CODE F33C32PL-B



8,4 kg
 500
 500 500

3-WEG ECKE | 3-WAY CORNER C33 PL
 CODE F33C33PL-B



8,4 kg
 500
 500 500

3-WEG ECKE | 3-WAY CORNER C34 PL
 CODE F33C34PL-B



8,4 kg
 290
 500 500

X-STÜCK | JOINT C41 PL
 CODE F33C41PL-B



9,3 kg
 260
 500 500

T-STÜCK | JOINT T36 PL
 CODE F33T36PL-B



8,4 kg
 260
 500 500

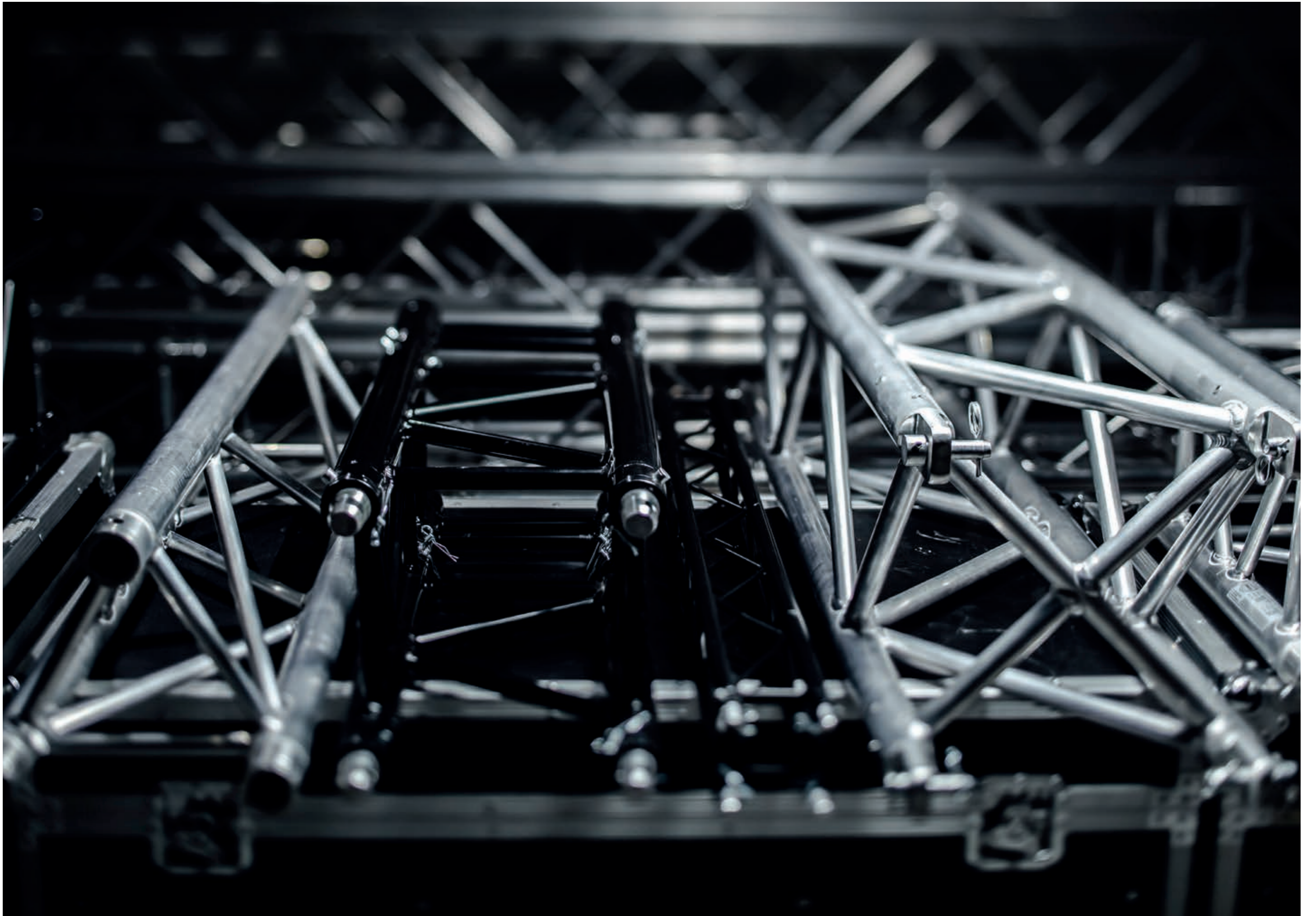

F34

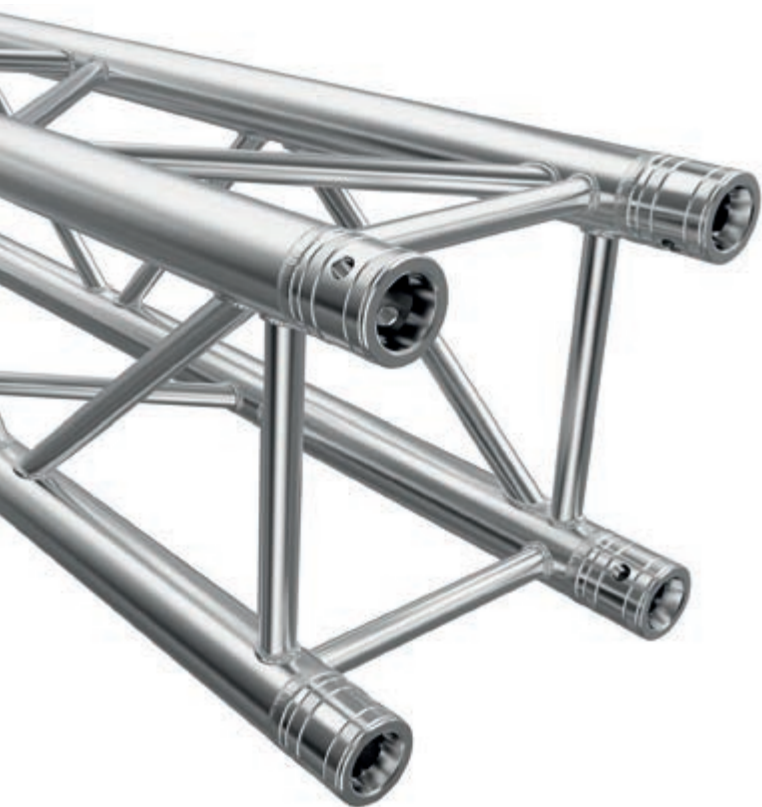

Das F34 Traversensystem von Global Truss ist ein TÜV-geprüftes 4-Punkt System mit einem Außenmaß von 29 cm. Aufgrund der idealen Traglast im Verhältnis zum Eigengewicht und den Außenmaßen zählt diese Traverse zu den beliebtesten Systemen auf dem Markt. Die Traversen dieser Serie eignen sich zum Messe- und Ladenbau, sowie als Traversen für Bühnendächer und weitere Outdooranwendungen. Ausgelegt ist dieses Traversensystem für eine Spannweite bis zu 18m.

Die F34 Traverse wird mit 50x2mm Gurtröhren und 20x2mm Diagonalbracings aus Aluminium gefertigt. Verbunden werden die Traversen über konische Verbinder, welche im Lieferumfang enthalten sind. Wie alle Global Truss Traversen lässt sich auch diese in beliebigen Farben pulverbeschichten.

The F34 truss series by Global Truss is a TÜV approved 4-point system with an external dimension of 29cm. Due to its perfect load capacity in relation to its weight and dimensions this system is one of the most commonly used. Exhibition stands and shop fittings as well as stage roofs and other outdoor applications can be built with the trusses of the F34 system. The system offers a maximum span of up to 18 meters.

The F34 truss is built with 50 x 2mm main tubes and 20 x 2mm diagonal braces of aluminium. The truss pieces are connected with the included conical connectors. This truss and all other Global Truss series can be powder coated in every RAL colour.

TECHNISCHE DATEN

Rohrdurchmesser Hauptrohr:	50 mm
Wandstärke:	2,0 mm
Material:	Al EN AW-6082 T6
Rohrdurchmesser Brace:	20 mm
Konische Verbinder	enthalten

TECHNICAL DATA

Pipe diameter:	50 mm
Wall thickness:	2,0 mm
Material:	Al EN AW-6082 T6
Brace diameter:	20 mm
Connectors	included



GERADEN | STRAIGHTS

CODE	Länge length	Gewicht weight
F34017	17 cm	2,1 kg
F34018	18 cm	2,2 kg
F34019	19 cm	2,3 kg
F34020	20 cm	2,4 kg
F34021	21 cm	2,5 kg
F34022	22 cm	2,6 kg
F34023	23 cm	2,7 kg
F34024	24 cm	2,8 kg
F34025	25 cm	2,9 kg
F34029	29 cm	3,0 kg
F34040	40 cm	4,7 kg
F34050	50 cm	4,9 kg
F34055	55 cm	6,2 kg
F34060	60 cm	6,4 kg
F34065	65 cm	6,6 kg
F34070	70 cm	6,8 kg
F34075	75 cm	7,0 kg
F34080	80 cm	7,2 kg
F34100	100 cm	7,5 kg
F34150	150 cm	9,7 kg
F34200	200 cm	12,0 kg
F34250	250 cm	14,0 kg
F34300	300 cm	16,0 kg
F34350	350 cm	19,0 kg
F34400	400 cm	21,0 kg
F34450	450 cm	23,6 kg
F34500	500 cm	25,9 kg



KREISSTÜCKE | CIRCLE PARTS

CODE	Ø Kreis circle	Kreisstück circle part	Gewicht weight
F34R10-180	2,0 m	1 Stück 180°	17,0 kg
F34R15-45	3,0 m	1 Stück 45°	7,0 kg
F34R15-60	3,0 m	1 Stück 60°	9,0 kg
F34R15-90	3,0 m	1 Stück 90°	13,0 kg
F34R20-45	4,0 m	1 Stück 45°	8,5 kg
F34R20-90	4,0 m	1 Stück 90°	16,4 kg
F34R25-45	5,0 m	1 Stück 45°	13,1 kg
F34R30-30	6,0 m	1 Stück 30°	13,4 kg
F34R30-45	6,0 m	1 Stück 45°	15,0 kg
F34R30-60	6,0 m	1 Stück 60°	16,2 kg
F34R35-45	7,0 m	1 Stück 45°	15,0 kg
F34R40-45	8,0 m	1 Stück 45°	16,5 kg
F34R45-45	9,0 m	1 Stück 45°	19,0 kg
F34R50-30	10,0 m	1 Stück 30°	15,5 kg
F34R55-30	11,0 m	1 Stück 30°	18,2 kg
F34R60-30	12,0 m	1 Stück 30°	22,1 kg

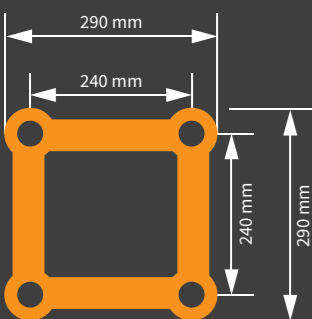

LOAD TABLE

Span	Uniform distribution load	Deflection	Center point load	Deflection	Point load in third-point	Deflection	Point load in quarter-point	Deflection	Point load in fifth-point	Deflection
m	kg / m	cm	kg	cm	kg	cm	kg	cm	kg	cm
4,00	501,00	1,36	922,00	1,01	627,00	1,16	496,00	1,28	393,00	1,29
5,00	344,00	2,30	763,00	1,64	528,00	1,93	411,00	2,09	324,00	2,09
6,00	241,00	3,36	649,00	2,43	455,00	2,89	346,00	3,06	274,00	3,09
7,00	177,00	4,61	562,00	3,39	398,00	4,06	297,00	4,22	237,00	4,29
8,00	135,00	6,06	494,00	4,51	353,00	5,42	260,00	5,56	208,00	5,68
9,00	106,00	7,71	440,00	5,80	316,00	7,00	230,00	7,10	185,00	7,28
10,00	85,00	9,55	395,00	7,26	285,00	8,77	205,00	8,82	166,00	9,07
11,00	69,00	11,60	357,00	8,89	258,00	10,76	185,00	10,75	150,00	11,08
12,00	58,00	13,85	324,00	10,71	236,00	12,97	168,00	12,87	136,00	13,29
13,00	48,00	16,29	296,00	12,71	216,00	15,39	153,00	15,19	125,00	15,70
14,00	41,00	18,95	271,00	14,91	199,00	18,03	140,00	17,71	114,00	18,33
15,00	35,00	21,81	249,00	17,30	183,00	20,89	128,00	20,44	105,00	21,18
16,00	30,00	24,88	229,00	19,90	169,00	23,99	118,00	23,38	97,00	24,24
17,00	26,00	28,16	211,00	22,71	157,00	27,32	109,00	26,53	89,00	27,52
18,00	23,00	31,65	195,00	25,74	146,00	30,89	100,00	29,90	82,00	31,03

Das Eigengewicht der Traverse ist in der Belastungstabelle berücksichtigt.
The dead load of the truss is considered in the load table.

BODENPLATTE | BASE PLATE



MULTI BOX CORNER



HALBKONUS FÜR BOXCORNER



VARIABLE ECKE | CORNER 0-180°
Der Winkel ist nur von ca. 20° bis 75° mit der mitgelieferten Stange arretierbar.
CODE F34VC0-180

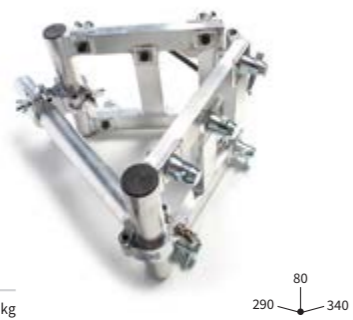

45° ECKE | CORNER C19
CODE F34C19

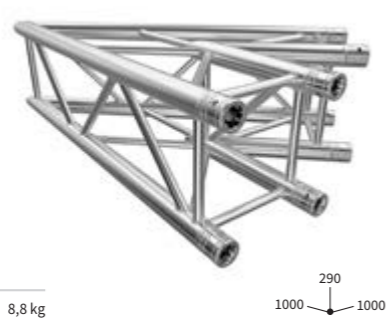

60° ECKE | CORNER C20
CODE F34C20

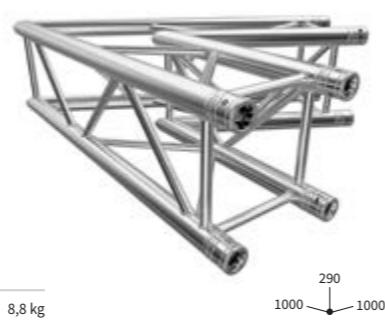

3-WEGE ECKE | 3-WAY CORNER C30 mit 85° Abgang links / with 85° joint left
CODE F34C30-85L

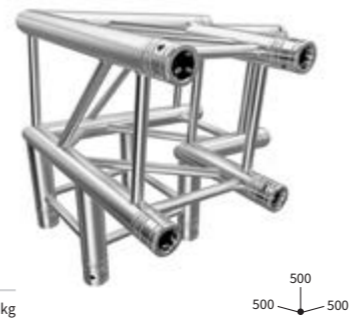

3-WEGE ECKE | 3-WAY CORNER C30 mit 85° Abgang rechts / with 85° joint right
CODE F34C30-85R



3-WEGE ECKE | 3-WAY CORNER C30 mit 95° Abgang links / with 95° joint left
CODE F34C30-95L



90° ECKE | CORNER C21
CODE F34C21

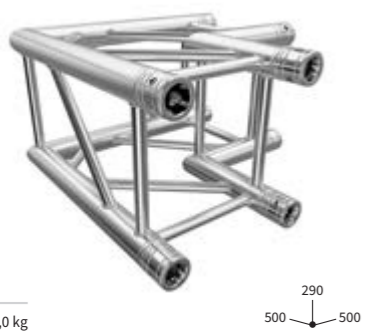

90° ECKE | CORNER C21 mit abgerundeten Ecken
CODE F34C21-R500



120° ECKE | CORNER C22
CODE F34C22

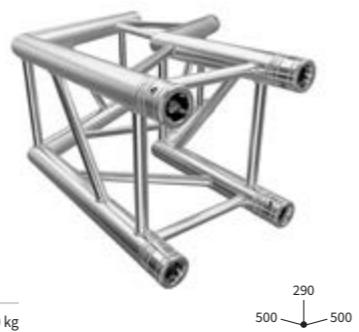

3-WEGE ECKE | 3-WAY CORNER C30 mit 95° Abgang rechts / with 95° joint right
CODE F34C30-95R

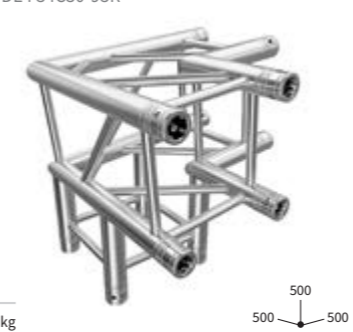

SPINDEL | SPINDLE
CODE F34SPINDEL
Höhe von 35 - 70 cm verstellbar
Height from 35 - 70 cm adjustable



F34 P 50CM FÜR ELEKTROKETTENZÜGE
F34 P 50CM FOR MOTOR HOIST
Compatible with F34 and F34P
CODE F34050P-M



135° ECKE | CORNER C23
CODE F34C23

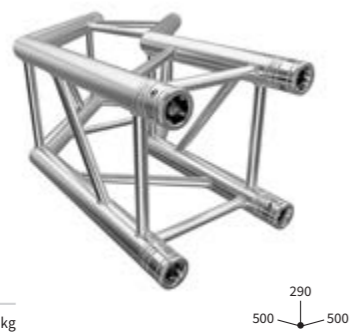

90° ECKE | CORNER C30
CODE F34C30



X-STÜCK | JOINT C41
CODE F34C41



X-STÜCK | JOINT C55
CODE F34C55

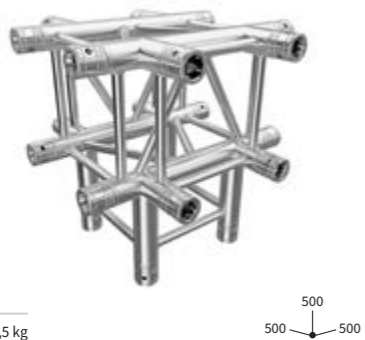

T-STÜCK | JOINT T35
CODE F34T35

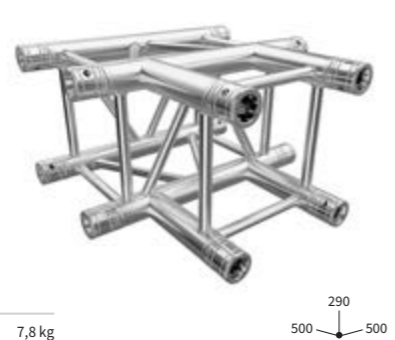

T-STÜCK | JOINT T40
CODE F34T40

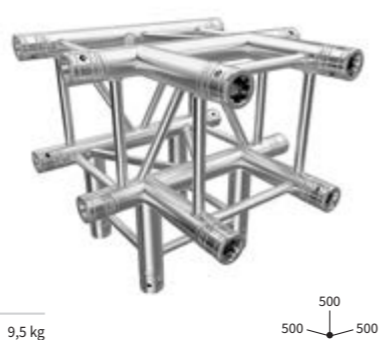

F34-B



Das F34 Traversensystem von Global Truss ist ein TÜV-geprüftes 4-Punkt System mit einem Außenmaß von 29 cm. Aufgrund der idealen Traglast im Verhältnis zum Eigengewicht und den Außenmaßen zählt diese Traverse zu den beliebtesten Systemen auf dem Markt. Die Traversen dieser Serie eignen sich zum Messe- und Ladenbau, sowie als Traversen für Bühnendächer und weitere Outdooranwendungen. Ausgelegt ist dieses Traversensystem für eine Spannweite bis zu 18m.

Die F34 Traverse wird mit 50x2mm Gurtröhren und 20x2mm Diagonalbracings aus Aluminium gefertigt. Verbunden werden die Traversen über konische Verbinder, welche im Lieferumfang enthalten sind.

The F34 truss series by Global Truss is a TÜV approved 4-point system with an external dimension of 29cm. Due to its perfect load capacity in relation to its weight and dimensions this system is one of the most commonly used. Exhibition stands and shop fittings as well as stage roofs and other outdoor applications can be built with the trusses of the F34 system. The system offers a maximum span of up to 18 meters.

The F34 truss is built with 50 x 2mm main tubes and 20 x 2mm diagonal braces of aluminium. The truss pieces are connected with the included conical connectors.

TECHNISCHE DATEN

Rohrdurchmesser Hauptrohr:	50 mm
Wandstärke:	2,0 mm
Material:	Al EN AW-6082 T6
Rohrdurchmesser Brace:	20 mm
Konische Verbinder	enthalten

TECHNICAL DATA

Pipe diameter:	50 mm
Wall thickness:	2,0 mm
Material:	Al EN AW-6082 T6
Brace diameter:	20 mm
Connectors	included



GERADEN | STRAIGHTS

CODE	Länge length	Gewicht weight
F34021-B	21 cm	2,5 kg
F34025-B	25 cm	2,9 kg
F34029-B	29 cm	3,0 kg
F34050-B	50 cm	4,9 kg
F34100-B	100 cm	7,5 kg
F34150-B	150 cm	9,7 kg
F34200-B	200 cm	12,0 kg
F34250-B	250 cm	14,0 kg
F34300-B	300 cm	16,0 kg

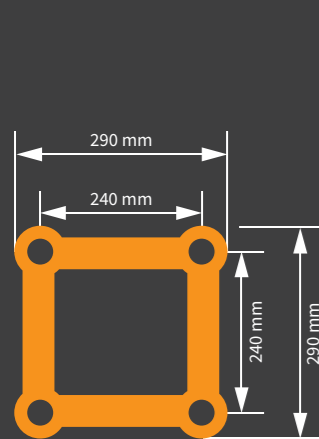

LOAD TABLE

Span	Uniform distribution load	Deflection	Center point load	Deflection	Point load in third-point	Deflection	Point load in quarter-point	Deflection	Point load in fifth-point	Deflection
m	kg / m	cm	kg	cm	kg	cm	kg	cm	kg	cm
4,00	501,00	1,36	922,00	1,01	627,00	1,16	496,00	1,28	393,00	1,29
5,00	344,00	2,30	763,00	1,64	528,00	1,93	411,00	2,09	324,00	2,09
6,00	241,00	3,36	649,00	2,43	455,00	2,89	346,00	3,06	274,00	3,09
7,00	177,00	4,61	562,00	3,39	398,00	4,06	297,00	4,22	237,00	4,29
8,00	135,00	6,06	494,00	4,51	353,00	5,42	260,00	5,56	208,00	5,68
9,00	106,00	7,71	440,00	5,80	316,00	7,00	230,00	7,10	185,00	7,28
10,00	85,00	9,55	395,00	7,26	285,00	8,77	205,00	8,82	166,00	9,07
11,00	69,00	11,60	357,00	8,89	258,00	10,76	185,00	10,75	150,00	11,08
12,00	58,00	13,85	324,00	10,71	236,00	12,97	168,00	12,87	136,00	13,29
13,00	48,00	16,29	296,00	12,71	216,00	15,39	153,00	15,19	125,00	15,70
14,00	41,00	18,95	271,00	14,91	199,00	18,03	140,00	17,71	114,00	18,33
15,00	35,00	21,81	249,00	17,30	183,00	20,89	128,00	20,44	105,00	21,18
16,00	30,00	24,88	229,00	19,90	169,00	23,99	118,00	23,38	97,00	24,24
17,00	26,00	28,16	211,00	22,71	157,00	27,32	109,00	26,53	89,00	27,52
18,00	23,00	31,65	195,00	25,74	146,00	30,89	100,00	29,90	82,00	31,03

Das Eigengewicht der Traverse ist in der Belastungstabelle berücksichtigt.
The dead load of the truss is considered in the load table.

90° ECKE | CORNER C21
CODE F34C21-B

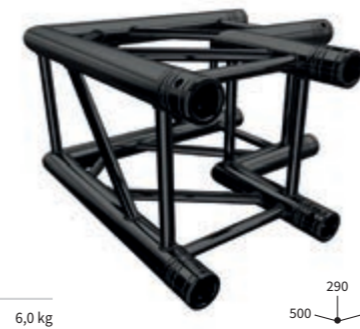

6,0 kg

90° ECKE | CORNER C30
CODE F34C30-B



11,5 kg

X-STÜCK | JOINT C41
CODE F34C41-B



8,8 kg

BODENPLATTE | BASE PLATE
CODE F34BASE-B



1,0 kg

T-STÜCK | JOINT T35
CODE F34T35-B



7,8 kg

T-STÜCK | JOINT T40
CODE F34T40-B

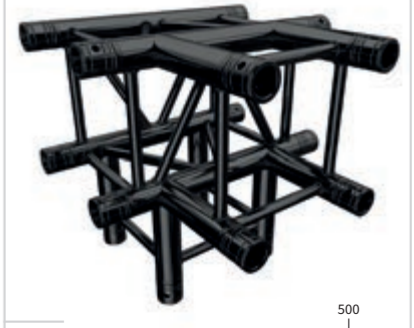

9,5 kg

TOWER TOOLS

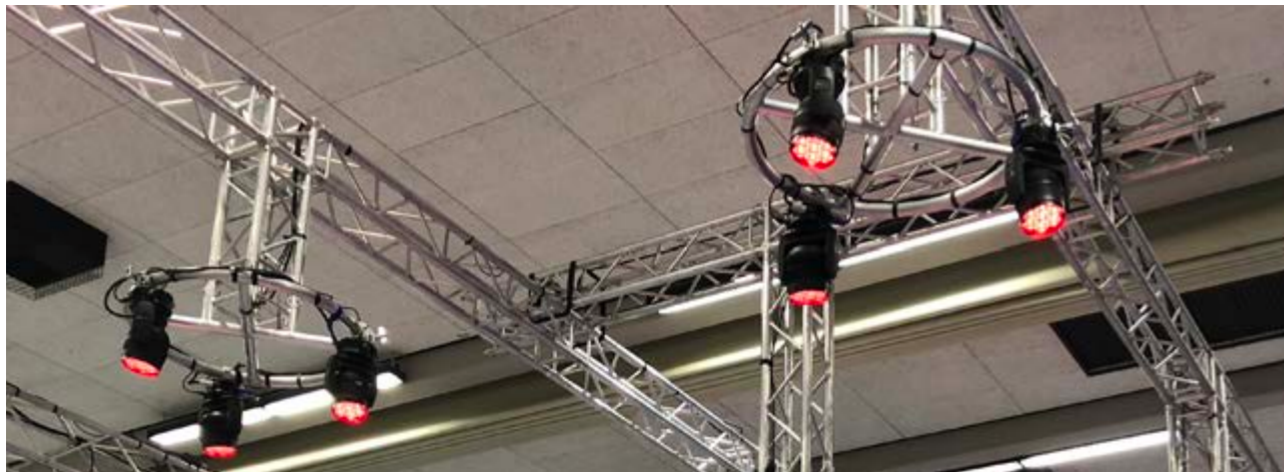

F34 TOWER RING 100

CODE 112277

TECHNISCHE DATEN

Durchmesser:	100 cm
Höhe:	50 cm
Rohrdurchmesser:	50 mm
Wandstärke:	2 mm
Konische Verbinder	enthalten

TECHNICAL DATA

Diameter:	100 cm
Height:	50 cm
Pipe diameter:	50 mm
Wall thickness:	2 mm
Conical connectors	included

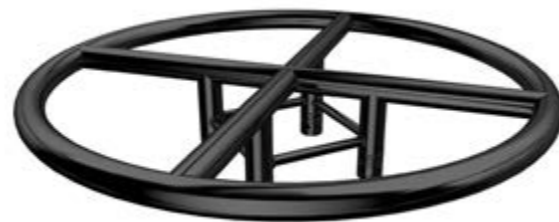

F34 TOP RING 100

CODE 112276
CODE 112276-B

TECHNISCHE DATEN

Rohrdurchmesser Hauptrohr:	50 mm
Wandstärke:	2,0 mm
Material:	Al EN AW-6082 T6
Rohrdurchmesser Brace:	20 mm
Konische Verbinder	enthalten

TECHNICAL DATA

Pipe diameter:	50 mm
Wall thickness:	2,0 mm
Material:	Al EN AW-6082 T6
Brace diameter:	20 mm
Connectors	included

F34 PL TOP RING 100

CODE 115311

TECHNISCHE DATEN

Rohrdurchmesser Hauptrohr:	48 mm
Wandstärke:	3,0 mm
Material:	Al EN AW-6082 T6
Rohrdurchmesser Brace:	20 mm
Konische Verbinder	enthalten

TECHNICAL DATA

Pipe diameter:	48 mm
Wall thickness:	3,0 mm
Material:	Al EN AW-6082 T6
Brace diameter:	20 mm
Connectors	included

F24 TOP RING 100

CODE 114515

TECHNISCHE DATEN

Rohrdurchmesser Hauptrohr:	35 mm
Wandstärke:	1,6 mm
Material:	Al EN AW-6082 T6
Rohrdurchmesser Brace:	8 mm
Konische Verbinder	enthalten

TECHNICAL DATA

Pipe diameter:	35 mm
Wall thickness:	1,6 mm
Material:	Al EN AW-6082 T6
Brace diameter:	8 mm
Connectors	included

F34 TOP TUBE

CODE F34TOPTUBE

CODE F34TOPTUBE-B

TECHNISCHE DATEN

Rohrdurchmesser Hauptrohr:	50 mm
Wandstärke:	2,0 mm
Material:	Al EN AW-6082 T6
Rohrdurchmesser Brace:	20 mm

TECHNICAL DATA

Pipe diameter:	50 mm
Wall thickness:	2,0 mm
Material:	Al EN AW-6082 T6
Brace diameter:	20 mm

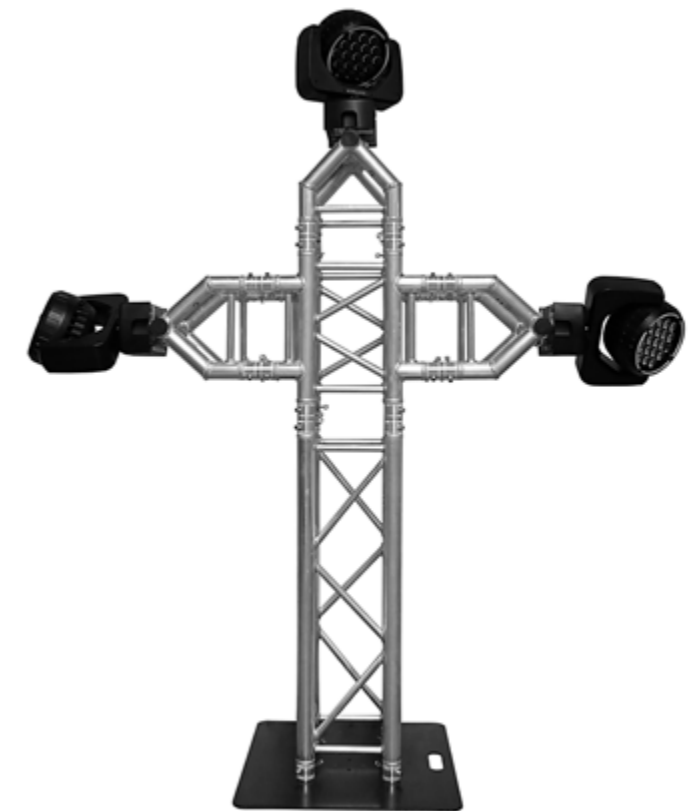

F34P



Das F34P Traversensystem von Global Truss ist ein TÜV-geprüftes 4-Punkt System mit einem Außenmaß von 29 cm. Aufgrund der idealen Traglast im Verhältnis zum Eigengewicht und den Außenmaßen zählt diese Traverse zu den beliebtesten Systemen auf dem Markt. Die Traversen dieser Serie eignen sich zum Messe- und Ladenbau, sowie als Traversen für Bühnendächer und weitere Outdooranwendungen. Durch die Erhöhung der Gurtröhrendicke sind höhere Lasten gegenüber der F34 Traverse möglich, wobei beide Systeme miteinander kombinierbar sind. Ausgelegt ist dieses Traversensystem für eine Spannweite bis zu 18m.

Die F34P Traverse wird mit 50x3mm Gurtröhren und 20x2mm Diagonalbracings aus Aluminium gefertigt. Verbunden werden die Traversen über konische Verbinder, welche im Lieferumfang enthalten sind. Wie alle Global Truss Traversen lässt sich auch diese in beliebigen Farben pulverbeschichten.

The F34P truss series by Global Truss is a TÜV approved 4-point system with an external dimension of 29cm. Due to its perfect load capacity in relation to its weight and dimensions this system is one of the most commonly used. Exhibition stands and shop fittings as well as stage roofs and other outdoor applications can be built with the trusses of the F34P system. Due to the higher wall thickness compared to the F34 truss it offers a greater load capacity, nevertheless both systems are compatible. The system offers a maximum span of up to 18 meters.

The F34P truss is built with 50 x 3mm main tubes and 20 x 2mm diagonal braces of aluminium. The truss pieces are connected with the included conical connectors. This truss and all other Global Truss series can be powder coated in every RAL colour.

TECHNISCHE DATEN

Rohrdurchmesser Hauptrohr: 50 mm
 Wandstärke: 3,0 mm
 Material: Al EN AW-6082 T6
 Rohrdurchmesser Brace: 20 mm
 Konische Verbinder: enthalten

TECHNICAL DATA

Pipe diameter: 50 mm
 Wall thickness: 3,0 mm
 Material: Al EN AW-6082 T6
 Brace diameter: 20 mm
 Connectors: included



LOAD TABLE

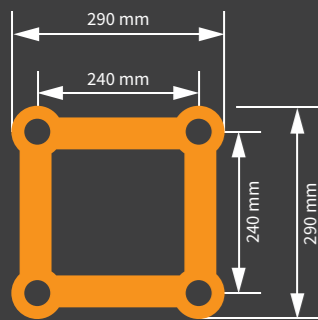

Span	Uniform distribution load	Deflection	Center point load	Deflection	Point load in third-point	Deflection	Point load in quarter-point	Deflection	Point load in fifth-point	Deflection
m	kg / m	cm	kg	cm	kg	cm	kg	cm	kg	cm
4,00	500,00	0,93	1350,00	1,00	911,00	1,15	667,00	1,17	500,00	1,12
5,00	399,00	1,82	1120,00	1,63	774,00	1,92	605,00	2,09	476,00	2,09
6,00	331,00	3,14	954,00	2,42	668,00	2,88	509,00	3,05	403,00	3,08
7,00	261,00	4,61	829,00	3,37	586,00	4,04	438,00	4,21	350,00	4,27
8,00	200,00	6,06	730,00	4,49	520,00	5,40	384,00	5,55	308,00	5,66
9,00	157,00	7,70	651,00	5,76	467,00	6,96	341,00	7,08	274,00	7,25
10,00	126,00	9,54	586,00	7,21	422,00	8,73	305,00	8,80	247,00	9,04
11,00	104,00	11,58	531,00	8,83	384,00	10,71	276,00	10,71	224,00	11,04
12,00	86,00	13,82	484,00	10,62	352,00	12,89	251,00	12,82	204,00	13,23
13,00	73,00	16,26	444,00	12,59	324,00	15,29	229,00	15,12	187,00	15,64
14,00	62,00	18,91	408,00	14,75	299,00	17,91	211,00	17,63	172,00	18,25
15,00	53,00	21,75	377,00	17,09	277,00	20,74	194,00	20,33	159,00	21,07
16,00	46,00	24,81	349,00	19,63	257,00	23,80	179,00	23,24	147,00	24,11
17,00	40,00	28,07	323,00	22,37	239,00	27,08	166,00	26,35	136,00	27,35
18,00	35,00	31,54	301,00	25,31	223,00	30,59	154,00	29,68	127,00	30,82

Das Eigengewicht der Traverse ist in der Belastungstabelle berücksichtigt.
 The dead load of the truss is considered in the load table.

GERADEN | STRAIGHTS

CODE	Länge length	Gewicht weight
F34021P	21 cm	4,0 kg
F34025P	25 cm	4,0 kg
F34050P	50 cm	6,0 kg
F34100P	100 cm	9,0 kg
F34150P	150 cm	12,0 kg
F34200P	200 cm	16,0 kg
F34250P	250 cm	19,0 kg
F34300P	300 cm	20,0 kg
F34350P	350 cm	23,0 kg
F34400P	400 cm	25,0 kg
F34450P	450 cm	28,0 kg
F34500P	500 cm	31,0 kg



F34 P 50CM FÜR ELEKTROKETTENZÜGE
 F34 P 50CM FOR MOTOR HOIST
 Compatible with F34 and F34P
 CODE F34050P-M



5,2 kg 290 500

90° ECKE | CORNER C21 P
 CODE F34C21P



9,1 kg 290 500

90° ECKE | CORNER C30 P
 CODE F34C30P



12,2 kg 500 500

X-STÜCK | JOINT C41 P
 CODE F34C41P



11,1 kg 290 500

X-STÜCK | JOINT C55 P
 CODE F34C55P



14,2 kg 500 500

T-STÜCK | JOINT T35 P
 CODE F34T35P



10,6 kg 290 500

T-STÜCK | JOINT T40 P
 CODE F34T40P



14,0 kg 500 500

BODENPLATTE | BASE PLATE P
 CODE F34BASE



1,0 kg 50 300

MULTI BOX CORNER P
 M12 Gewinde / M12 thread
 CODE F34MULTIBOX

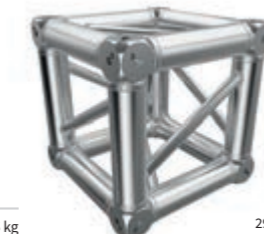

5,6 kg 290 290

HALBKONUS FÜR BOXCORNER
 HALFCONNECTOR FOR BOX CORNER
 CODE F34BOXC M10
 CODE F34BOXD M12



F34P-B



Das F34P Traversensystem von Global Truss ist ein TÜV-geprüftes 4-Punkt System mit einem Außenmaß von 29 cm. Aufgrund der idealen Traglast im Verhältnis zum Eigengewicht und den Außenmaßen zählt diese Traverse zu den beliebtesten Systemen auf dem Markt. Die Traversen dieser Serie eignen sich zum Messe- und Ladenbau, sowie als Traversen für Bühnendächer und weitere Outdooranwendungen. Durch die Erhöhung der Gurtröhrendicke sind höhere Lasten gegenüber der F34 Traverse möglich, wobei beide Systeme miteinander kombinierbar sind. Ausgelegt ist dieses Traversensystem für eine Spannweite bis zu 18m.

Die F34P Traverse wird mit 50x3mm Gurtröhren und 20x2mm Diagonalbracings aus Aluminium gefertigt. Verbunden werden die Traversen über konische Verbinder, welche im Lieferumfang enthalten sind.

The F34P truss series by Global Truss is a TÜV approved 4-point system with an external dimension of 29cm. Due to its perfect load capacity in relation to its weight and dimensions this system is one of the most commonly used. Exhibition stands and shop fittings as well as stage roofs and other outdoor applications can be built with the trusses of the F34P system. Due to the higher wall thickness compared to the F34 truss it offers a greater load capacity, nevertheless both systems are compatible. The system offers a maximum span of up to 18 meters.

The F34P truss is built with 50 x 3mm main tubes and 20 x 2mm diagonal braces of aluminium. The truss pieces are connected with the included conical connectors.

GERADEN | STRAIGHTS

CODE	Länge length	Gewicht weight
F34021P-B	21 cm	4,0 kg
F34025P-B	25 cm	4,0 kg
F34050P-B	50 cm	6,0 kg
F34100P-B	100 cm	9,0 kg
F34150P-B	150 cm	12,0 kg
F34200P-B	200 cm	16,0 kg
F34250P-B	250 cm	19,0 kg
F34300P-B	300 cm	20,0 kg



TECHNISCHE DATEN

Rohrdurchmesser Hauptrohr:	50 mm
Wandstärke:	3,0 mm
Material:	Al EN AW-6082 T6
Rohrdurchmesser Brace:	20 mm
Konische Verbinder	enthalten

TECHNICAL DATA

Pipe diameter:	50 mm
Wall thickness:	3,0 mm
Material:	Al EN AW-6082 T6
Brace diameter:	20 mm
Connectors	included

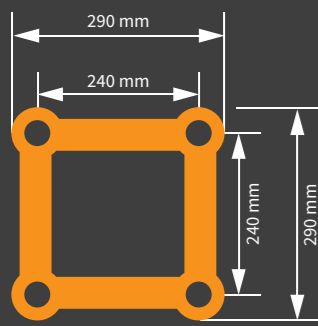

LOAD TABLE

Span	Uniform distribution load	Deflection		Center point load		Deflection		Point load in third-point		Deflection		Point load in quarter-point		Deflection		Point load in fifth-point		Deflection	
		cm	kg	cm	kg	cm	kg	cm	kg	cm	kg	cm	kg	cm	kg	cm	kg		
4,00	500,00	0,93	1350,00	1,00	911,00	1,15	667,00	1,17	500,00	1,12	4,00	500,00	1,12	4,00	500,00	1,12	4,00	500,00	1,12
5,00	399,00	1,82	1120,00	1,63	774,00	1,92	605,00	2,09	476,00	2,09	5,00	399,00	2,09	5,00	399,00	2,09	5,00	399,00	2,09
6,00	331,00	3,14	954,00	2,42	668,00	2,88	509,00	3,05	403,00	3,08	6,00	331,00	3,08	6,00	331,00	3,08	6,00	331,00	3,08
7,00	261,00	4,61	829,00	3,37	586,00	4,04	438,00	4,21	350,00	4,27	7,00	261,00	4,27	7,00	261,00	4,27	7,00	261,00	4,27
8,00	200,00	6,06	730,00	4,49	520,00	5,40	384,00	5,55	308,00	5,66	8,00	200,00	5,66	8,00	200,00	5,66	8,00	200,00	5,66
9,00	157,00	7,70	651,00	5,76	467,00	6,96	341,00	7,08	274,00	7,25	9,00	157,00	7,25	9,00	157,00	7,25	9,00	157,00	7,25
10,00	126,00	9,54	586,00	7,21	422,00	8,73	305,00	8,80	247,00	9,04	10,00	126,00	9,04	10,00	126,00	9,04	10,00	126,00	9,04
11,00	104,00	11,58	531,00	8,83	384,00	10,71	276,00	10,71	224,00	11,04	11,00	104,00	11,04	11,00	104,00	11,04	11,00	104,00	11,04
12,00	86,00	13,82	484,00	10,62	352,00	12,89	251,00	12,82	204,00	13,23	12,00	86,00	13,23	12,00	86,00	13,23	12,00	86,00	13,23
13,00	73,00	16,26	444,00	12,59	324,00	15,29	229,00	15,12	187,00	15,64	13,00	73,00	15,64	13,00	73,00	15,64	13,00	73,00	15,64
14,00	62,00	18,91	408,00	14,75	299,00	17,91	211,00	17,63	172,00	18,25	14,00	62,00	18,25	14,00	62,00	18,25	14,00	62,00	18,25
15,00	53,00	21,75	377,00	17,09	277,00	20,74	194,00	20,33	159,00	21,07	15,00	53,00	21,07	15,00	53,00	21,07	15,00	53,00	21,07
16,00	46,00	24,81	349,00	19,63	257,00	23,80	179,00	23,24	147,00	24,11	16,00	46,00	24,11	16,00	46,00	24,11	16,00	46,00	24,11
17,00	40,00	28,07	323,00	22,37	239,00	27,08	166,00	26,35	136,00	27,35	17,00	40,00	27,35	17,00	40,00	27,35	17,00	40,00	27,35
18,00	35,00	31,54	301,00	25,31	223,00	30,59	154,00	29,68	127,00	30,82	18,00	35,00	30,82	18,00	35,00	30,82	18,00	35,00	30,82

Das Eigengewicht der Traverse ist in der Belastungstabelle berücksichtigt.
The dead load of the truss is considered in the load table.

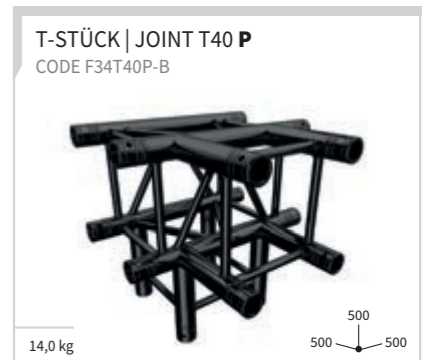

F34PL

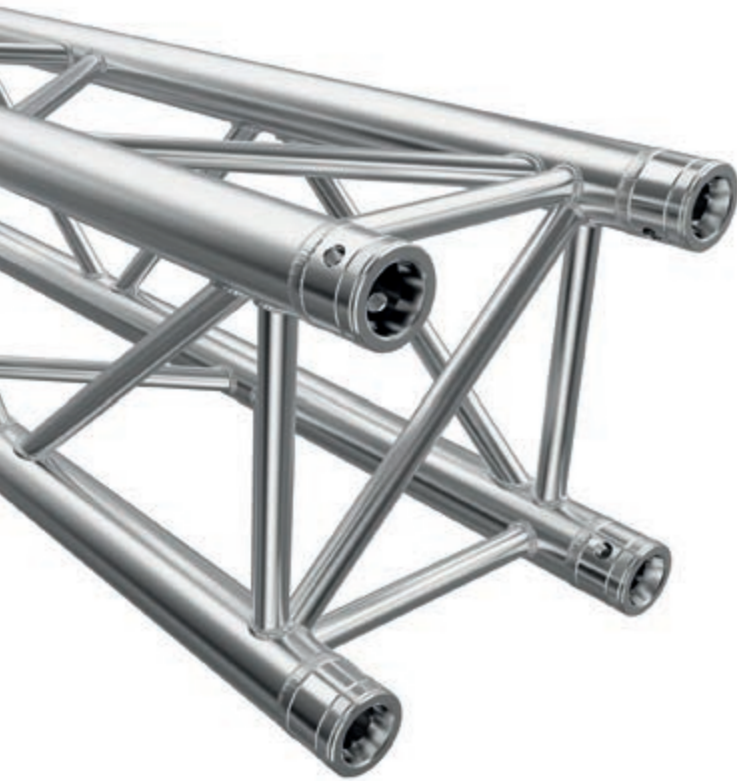

Das F34PL Traversensystem von Global Truss ist ein TÜV-geprüftes 4-Punkt System mit einem Außenmaß von 29 cm. Die Traversen dieser Serie eignen sich zum Messe- und Ladenbau, sowie als Traversen für Bühnendächer und weitere Outdooranwendungen. Ausgelegt ist dieses Traversensystem für eine Spannweite bis zu 18m.

Die F34PL Traverse wird mit 48x3mm Gurtrohren und 16x2mm Diagonalbracings aus Aluminium gefertigt. Verbunden werden die Traversen über konische Verbinder, welche im Lieferumfang enthalten sind. Wie alle Global Truss Traversen lässt sich auch diese in beliebigen Farben pulverbeschichten.

The F34PL truss series by Global Truss is a TÜV approved 4-point system with an external dimension of 29cm. Due to its perfect load capacity in relation to its weight and dimensions this system is one of the most commonly used. Exhibition stands and shop fittings as well as stage roofs and other outdoor applications can be built with the trusses of the F34PL system. Due to the higher wall thickness compared to the F34 truss it offers a greater load capacity and a maximum span of up to 18 meters.

The F34PL truss is built with 48 x 3mm main tubes and 20 x 2mm diagonal braces of aluminium. The truss pieces are connected with the included conical connectors. This truss and all other Global Truss series can be powder coated in every RAL colour.

TECHNISCHE DATEN

Rohrdurchmesser Hauptrohr:	48 mm
Wandstärke:	3,0 mm
Material:	Al EN AW-6082 T6
Rohrdurchmesser Brace:	16 x 2 mm
Konische Verbinder	enthalten

TECHNICAL DATA

Pipe diameter:	48 mm
Wall thickness:	3,0 mm
Material:	Al EN AW-6082 T6
Brace diameter:	16 x 2 mm
Connectors	included



GERADEN | STRAIGHTS

CODE	Länge length	Gewicht weight
F34017PL	17 cm	2,1 kg
F34018PL	18 cm	2,2 kg
F34019PL	19 cm	2,3 kg
F34020PL	20 cm	2,4 kg
F34021PL	21 cm	2,5 kg
F34022PL	22 cm	2,6 kg
F34023PL	23 cm	2,7 kg
F34024PL	24 cm	2,8 kg
F34025PL	25 cm	2,9 kg
F34025PL	29 cm	2,9 kg
F34050PL	50 cm	4,9 kg
F34055PL	55 cm	6,2 kg
F34060PL	60 cm	6,4 kg
F34065PL	65 cm	6,6 kg
F34070PL	70 cm	6,8 kg
F34075PL	75 cm	7,0 kg
F34100PL	100 cm	7,5 kg
F34150PL	150 cm	9,7 kg
F34200PL	200 cm	12,0 kg
F34250PL	250 cm	14,0 kg
F34300PL	300 cm	16,0 kg
F34350PL	350 cm	19,0 kg
F34400PL	400 cm	21,0 kg
F34450PL	450 cm	23,6 kg
F34500PL	500 cm	25,9 kg



KREISSTÜCKE | CIRCLE PARTS

CODE	Ø Kreis circle	Kreisstück circle part	Gewicht weight
F34R10-180PL	2,0 m	1 Stück 180°	17,0 kg
F34R15-90PL	3,0 m	1 Stück 90°	13,0 kg
F34R20-90PL	4,0 m	1 Stück 90°	16,4 kg
F34R25-45PL	5,0 m	1 Stück 45°	11,2 kg
F34R25-90PL	5,0 m	1 Stück 90°	19,0 kg
F34R30-60PL	6,0 m	1 Stück 60°	16,2 kg
F34R35-45PL	7,0 m	1 Stück 45°	15,0 kg
F34R40-45PL	8,0 m	1 Stück 45°	16,5 kg
F34R45-45PL	9,0 m	1 Stück 45°	19,0 kg
F34R50-30PL	10,0 m	1 Stück 30°	15,5 kg
F34R60-30PL	12,0 m	1 Stück 30°	17,9 kg



Span	LOAD TABLE											
	Uniform distribution load	Deflection	Center point load	Deflection	Point load in third-point	Deflection	Point load in quarter-point	Deflection	Point load in fifth-point	Deflection		
m	kg / m	cm	kg	cm	kg	cm	kg	cm	kg	cm		
4,00	427,00	0,83	1353,00	1,05	855,00	1,13	570,00	1,05	427,00	1,00		
5,00	341,00	1,62	1114,00	1,69	779,00	2,02	568,00	2,05	426,00	1,96		
6,00	283,00	2,80	944,00	2,50	671,00	3,01	496,00	3,11	398,00	3,17		
7,00	242,00	4,45	817,00	3,46	585,00	4,20	427,00	4,27	344,00	4,38		
8,00	193,00	6,11	719,00	4,59	518,00	5,59	373,00	5,62	302,00	5,78		
9,00	152,00	7,75	640,00	5,88	463,00	7,18	331,00	7,16	269,00	7,39		
10,00	122,00	9,60	575,00	7,33	418,00	8,98	297,00	8,89	242,00	9,20		
11,00	100,00	11,64	521,00	8,96	380,00	10,98	268,00	10,81	219,00	11,20		
12,00	83,00	13,88	475,00	10,76	348,00	13,19	244,00	12,92	200,00	13,42		
13,00	70,00	16,32	435,00	12,73	320,00	15,61	223,00	15,23	183,00	15,83		
14,00	60,00	18,96	401,00	14,89	295,00	18,25	205,00	17,74	168,00	18,46		
15,00	52,00	21,81	370,00	17,23	274,00	21,10	189,00	20,44	156,00	21,29		
16,00	45,00	24,86	343,00	19,76	254,00	24,17	175,00	23,35	144,00	24,33		
17,00	39,00	28,11	319,00	22,49	237,00	27,47	163,00	26,46	134,00	27,59		
18,00	34,00	31,57	296,00	25,41	221,00	30,99	151,00	29,78	125,00	31,06		

Das Eigengewicht der Traverse ist in der Belastungstabelle berücksichtigt.
The dead load of the truss is considered in the load table.

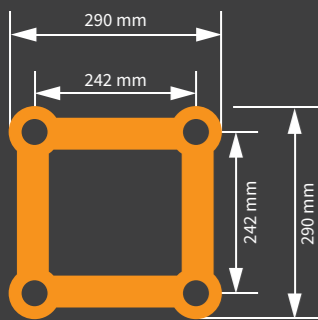

BODENPLATTE | BASE PLATE PL

CODE F34BASEPL



1,0 kg

MULTI BOX CORNER PL

M12 Gewinde
M12 thread
CODE F34MULTIBOX

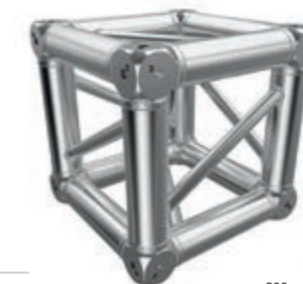

5,6 kg

45° ECKE | CORNER C19 PL

CODE F34C19PL



8,0 kg

60° ECKE | CORNER C20 PL
CODE F34C20PL

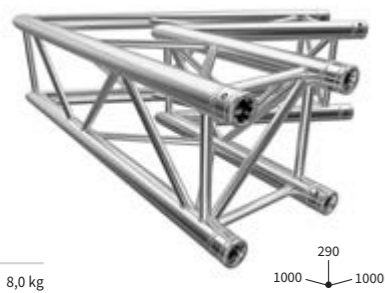

90° ECKE | CORNER C21 PL
CODE F34C21PL



120° ECKE | CORNER C22 PL
CODE F34C22PL

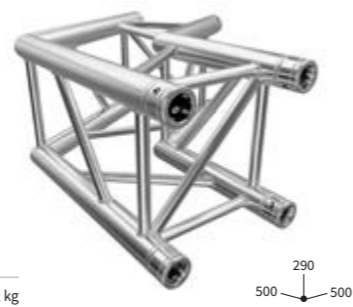

135° ECKE | CORNER C23 PL
CODE F34C23PL

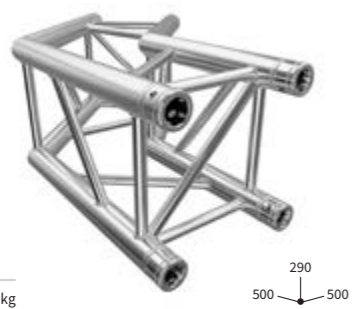

90° ECKE | CORNER C30 PL
CODE F34C30PL



X-STÜCK | JOINT C41 PL
CODE F34C41PL

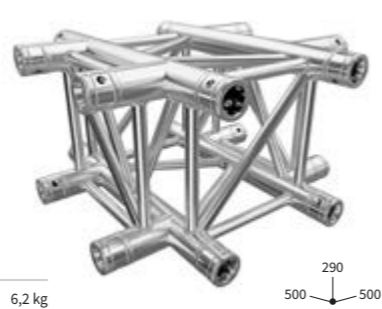

X-STÜCK | JOINT C55 PL
CODE F34C55PL

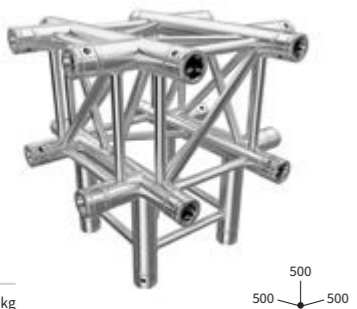

T-STÜCK | JOINT T35 500MM PL
CODE F34T35PL

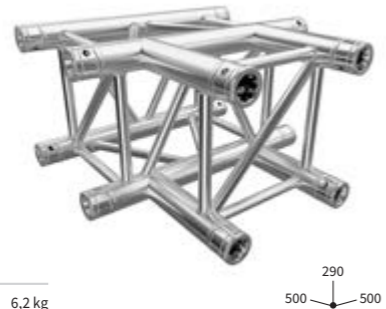

T-STÜCK | JOINT T35 710MM PL
CODE F34T35PL-710

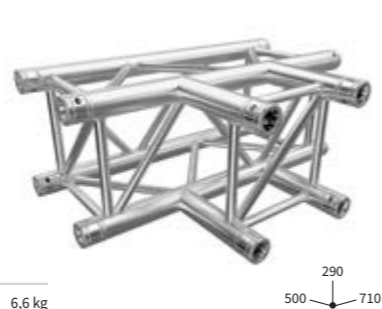

T-STÜCK | JOINT T40 PL
CODE F34T40PL

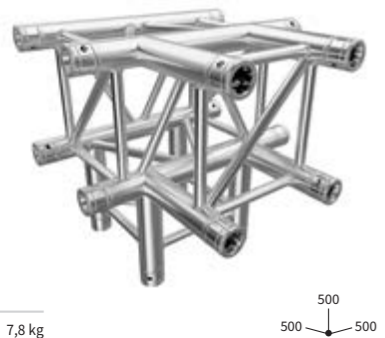

Zubehör/Accessories

VERBINDER SET
CONNECTOR SET
Konus, Bolzen & R-Clip
cone, pin and r-clip.
CODE 5002PL



BOLZEN | PIN
Bolzen mit M8 Gewinde
pin with M8 thread
CODE 5005PL



F34PL-B



Das F34PL Traversensystem von Global Truss ist ein TÜV-geprüftes 4-Punkt System mit einem Außenmaß von 29 cm. Die Traversen dieser Serie eignen sich zum Messe- und Ladenbau, sowie als Traversen für Bühnendächer und weitere Outdooranwendungen. Ausgelegt ist dieses Traversensystem für eine Spannweite bis zu 18m.

Die F34PL Traverse wird mit 48x3mm Gurtrohren und 16x2mm Diagonalbracings aus Aluminium gefertigt. Verbunden werden die Traversen über konische Verbinder, welche im Lieferumfang enthalten sind.

The F34P truss series by Global Truss is a TÜV approved 4-point system with an external dimension of 29cm. Due to its perfect load capacity in relation to its weight and dimensions this system is one of the most commonly used. Exhibition stands and shop fittings as well as stage roofs and other outdoor applications can be built with the trusses of the F34PL system. Due to the higher wall thickness compared to the F34 truss it offers a greater load capacity and a maximum span of up to 18 meters.

The F34PL truss is built with 48 x 3mm main tubes and 20 x 2mm diagonal braces of aluminium. The truss pieces are connected with the included conical connectors.

TECHNISCHE DATEN

Rohrdurchmesser Hauptrohr:	48 mm
Wandstärke:	3,0 mm
Material:	Al EN AW-6082 T6
Rohrdurchmesser Brace:	16 x 2 mm
Konische Verbinder	enthalten

TECHNICAL DATA

Pipe diameter:	48 mm
Wall thickness:	3,0 mm
Material:	Al EN AW-6082 T6
Brace diameter:	16 x 2 mm
Connectors	included



GERADEN | STRAIGHTS

CODE	Länge length	Gewicht weight
F34050PL-B	50 cm	4,9 kg
F34100PL-B	100 cm	7,5 kg
F34150PL-B	150 cm	9,7 kg
F34200PL-B	200 cm	12,0 kg
F34250PL-B	250 cm	14,0 kg
F34300PL-B	300 cm	16,0 kg



BODENPLATTE | BASE PLATE PL CODE F34BASEPL-B

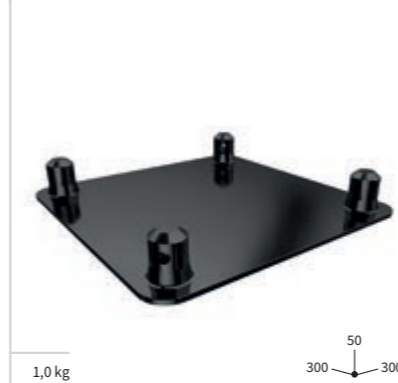

MULTI BOX CORNER PL M12 Gewinde M12 thread CODE F34MULTIBOX-B

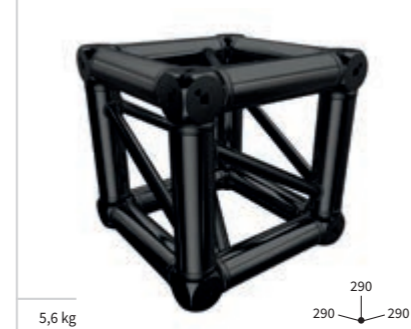

90° ECKE | CORNER C21 PL CODE F34C21PL-B



90° ECKE | CORNER C30 PL CODE F34C30PL-B



X-STÜCK | JOINT C41 PL CODE F34C41PL-B



T-STÜCK | JOINT T35 PL CODE F34T35PL-B



LOAD TABLE

Span	Uniform distribution load	Deflection		Center point load		Deflection		Point load in third-point		Deflection		Point load in quarter-point		Deflection		Point load in fifth-point		Deflection	
		cm	kg	cm	kg	cm	kg	cm	kg	cm	kg	cm	kg	cm	kg	cm	kg		
4,00	427,00	0,83	1353,00	1,05	855,00	1,13	570,00	1,05	427,00	1,05	427,00	1,00	1,00	1,00	1,00	1,00	1,00	1,00	1,00
5,00	341,00	1,62	1114,00	1,69	779,00	2,02	568,00	2,05	426,00	2,05	426,00	1,96	1,96	1,96	1,96	1,96	1,96	1,96	1,96
6,00	283,00	2,80	944,00	2,50	671,00	3,01	496,00	3,11	398,00	3,11	398,00	3,17	3,17	3,17	3,17	3,17	3,17	3,17	3,17
7,00	242,00	4,45	817,00	3,46	585,00	4,20	427,00	4,27	344,00	4,27	344,00	4,38	4,38	4,38	4,38	4,38	4,38	4,38	4,38
8,00	193,00	6,11	719,00	4,59	518,00	5,59	373,00	5,62	302,00	5,62	302,00	5,78	5,78	5,78	5,78	5,78	5,78	5,78	5,78
9,00	152,00	7,75	640,00	5,88	463,00	7,18	331,00	7,16	269,00	7,39	269,00	7,39	7,39	7,39	7,39	7,39	7,39	7,39	7,39
10,00	122,00	9,60	575,00	7,33	418,00	8,98	297,00	8,89	242,00	9,20	242,00	9,20	9,20	9,20	9,20	9,20	9,20	9,20	9,20
11,00	100,00	11,64	521,00	8,96	380,00	10,98	268,00	10,81	219,00	11,20	219,00	11,20	11,20	11,20	11,20	11,20	11,20	11,20	11,20
12,00	83,00	13,88	475,00	10,76	348,00	13,19	244,00	12,92	200,00	13,42	200,00	13,42	13,42	13,42	13,42	13,42	13,42	13,42	13,42
13,00	70,00	16,32	435,00	12,73	320,00	15,61	223,00	15,23	183,00	15,83	183,00	15,83	15,83	15,83	15,83	15,83	15,83	15,83	15,83
14,00	60,00	18,96	401,00	14,89	295,00	18,25	205,00	17,74	168,00	18,46	168,00	18,46	18,46	18,46	18,46	18,46	18,46	18,46	18,46
15,00	52,00	21,81	370,00	17,23	274,00	21,10	189,00	20,44	156,00	21,29	156,00	21,29	21,29	21,29	21,29	21,29	21,29	21,29	21,29
16,00	45,00	24,86	343,00	19,76	254,00	24,17	175,00	23,35	144,00	24,33	144,00	24,33	24,33	24,33	24,33	24,33	24,33	24,33	24,33
17,00	39,00	28,11	319,00	22,49	237,00	27,47	163,00	26,46	134,00	27,59	134,00	27,59	27,59	27,59	27,59	27,59	27,59	27,59	27,59
18,00	34,00	31,57	296,00	25,41	221,00	30,99	151,00	29,78	125,00	31,06	125,00	31,06	31,06	31,06	31,06	31,06	31,06	31,06	31,06

Das Eigengewicht der Traverse ist in der Belastungstabelle berücksichtigt.
The dead load of the truss is considered in the load table.

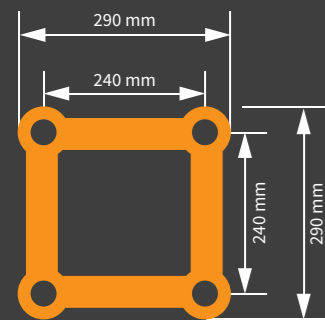

SLEEVE



F34 SLEEVE MIT STAHLINLETS

CODE F34S-SI

Mit dem Sleeve CA-3 ist ein Produkt der neuen Generation entstanden. Der Sleeve wurde speziell für den Bühnenbau entwickelt. Erstmals ist es möglich, die Traverse an unterschiedlichen Punkten anzuschlagen. Dies ist besonders im Bühnen- oder Messebau von Vorteil, da hier endlich keine Kanten mehr entstehen. Man kann die Fittings für mittige, rechts- oder linksbündige Montage anbringen. Aus Gewichtsgründen wurde ein neues Produktionsverfahren entwickelt: in dem neuartigen Aluminiumsleeve befinden sich an den statisch relevanten Positionen verschraubte Stahlinlets mit Fixierpunkt für die Fittings. Erstmals ist es somit möglich, ein Produkt mit den Eigenschaften eines Stahlsleeves und dem Gewicht eines Alusleeves herzustellen. Die zulässige Last bei Aufhängung am ungünstigsten Punkt in der Mitte des Obergurts beträgt $P = 1450\text{kg}$. In Einzelfällen (bei Anschluss an zwei, drei bzw. vier Seiten) kann die zulässige Gesamtbelastung, die hochgezogen werden darf, erhöht werden (z.B. für den gleichmäßig belasteten 4-seitigen Anschluss auf bis zu 3360kg)

The sleeve CA-3 is a new generation of sleeve blocks which has been specially developed for roof constructions. For the first time it is possible to mount the truss on different spots. This is especially an advantage when building roofs or stands because there are no more edges. The fittings can be applied centrally, left or right-justified. For weight reasons a new production method was developed: within the aluminum sleeve there are on all relevant static points screwed together steel inlets with fixing points for the fittings. It is now possible to create a product with the features of a steel sleeve and the weight of an aluminum sleeve. The permitted load when choosing the most unfavorable location of the top chord is $P = 1450\text{kg}$. In some cases (if connected on two, three or four sides) the permitted total load which has been lifted can be increased (e.g. if equally loaded on four sides up to 3360kg)

BASE F34 STAHL | STEEL
CODE F34BASEBE



F52 BASE
basierend auf F44P
based on F44P truss
CODE F52BA



F34 MULTI BASE
CODE F34MULTIBASE

Maße: 45 x 45 cm
Dimensions: 45 x 45 cm



F34 SPACER-ELEMENT
Spacer Element zum Tothängen des
Sleeveblocks
spacer element to save the sleeve
CODE F34SLEEVESAVE



KNICKELEMENTE
hinge elements



CODE 5029L links / left
CODE 5029R rechts / right
CODE 5029L-PL links / left (PL Version)
CODE 5029R-PL rechts / right (PL Version)
CODE 5029LQX links / left
CODE 5029RQX rechts / right

F34 BASE AUSLEGARM
F34 BASE FOR OUTRIGGER
CODE F34MULTIBASE-A



F34 TOP
CODE F34TOP



F44 TOP
CODE F44TOP



NIVELLIER-STANDFUSS

Screw jack

CODE 49238 30cm kurze Version / short version
CODE 49239 50cm lange Version / long version



SLEEVE ALU

CODE F34SLEEVE F-34
CODE F44SLEEVE F-44



F34 SLEEVE SLIDE
für horizontale Anwendung
for horizontal use

CODE F34SLIDESLEEVE



F52 SLEEVE
basierend auf F44P
based on F44P truss

CODE F52SLEEVE



HALBER KONUSVERBINDER

half conical adapter

F34BOXC für Boxcorner M10
F34BOXD für Boxcorner M12
5003S für Sleeve M10



KNICKELEMENTE VOLLMATERIAL

hinge elements (grave)

CODE 5029L-V links / left
CODE 5029R-V rechts / right



LEITER TRUSS

Ladder for F32 / F34

CODE F34L100 100cm / F34
CODE F34L200 200cm / F34
CODE F32L200 200cm / F32



GROUND SUPPORT

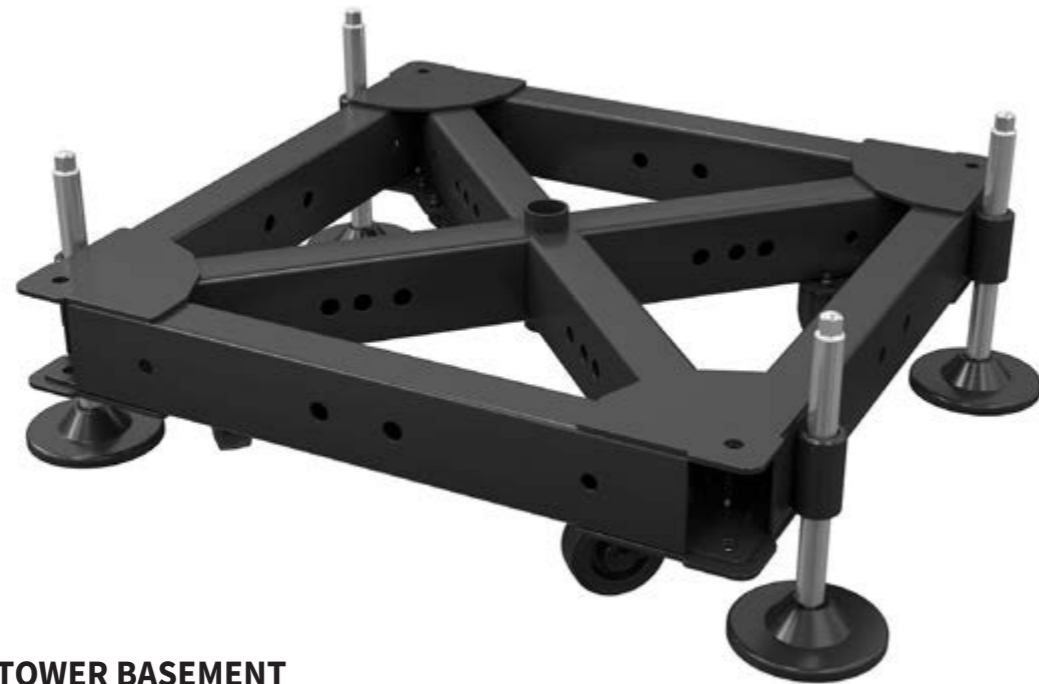

MULTI TOWER BASEMENT

CODE GT-MTB

Mit der neuen Multibase hat Global Truss ab sofort ein Basement im Programm, welches durch seine hochwertige Verarbeitung überzeugen kann. Es ist mit verschiedenen Traversensystemen nutzbar und lässt sich unter anderem auch als Groundsupport sowie für freistehende Towerkonstruktionen verwenden.

Global Truss offers with the new Multibase a multifunctional basement that convinces with our high quality standards. Furthermore it is useable with different truss systems and can be used as ground support as well as for free standing tower constructions.

TECHNISCHE DATEN

Maße: 80 x 98 x 34 cm
 Gewicht: 60,5 kg
 Material: Stahl
 KTL Pulverbeschichtet
 Kompatibel: F34, F44 & iM Type
 inkl. vier Spindelfüße mit M27 Gewinde

TECHNICAL DATA

Dimensions: 80 x 98 x 34 cm
 Weight: 60,5 kg
 Material: Steel
 KTL powder coated
 Compatible: F34, F44 & iM Type
 incl. four spindle feet with M27 thread

MTB KONUS ABGANG CODE GT-MTB/KA

Maße: 45 x 45 cm
Dimensions: 45 x 45 cm



F34 TOP CODE GT-MTB/GKA-V1

Maße: 45 x 45 cm
Dimensions: 45 x 45 cm



F34 TOP CODE GT-MTB/GKA-V2

Maße: 45 x 45 cm
Dimensions: 45 x 45 cm



PINS

CODE GT-MTB/PIN16-V1 16/50 MM
 CODE GT-MTB/PIN16-V2 16/132 MM
 CODE GT-MTB/PIN16-V2 20/107,3 MM



MTB PALLHOLZ CODE GT-MTB/PALL

Maße: 380 x 380 x 21 mm
Dimensions: 380 x 380 x 21 mm



MTB ABSPANNPUNKT CODE GT-MTB/ASP

Inklusive 2 Bolzen
Inclusive 2 bolt



MTB ADAPTER CODE GT-MTB/APT

Mit diesem Adapter lassen sich zwei Ausleger im 90° Winkel an der Multibase anbringen.
Dimensions: 45 x 45 cm



MTB MOTOR PICK POINT CODE GT-MTB/MPP

Maße: 45 x 45 cm
Dimensions: 45 x 45 cm



MTB OUTRIGGER CODE GT-MTB/OUT

Maße: 45 x 45 cm
Dimensions: 45 x 45 cm



GROUNDSUPPORT "ALU"

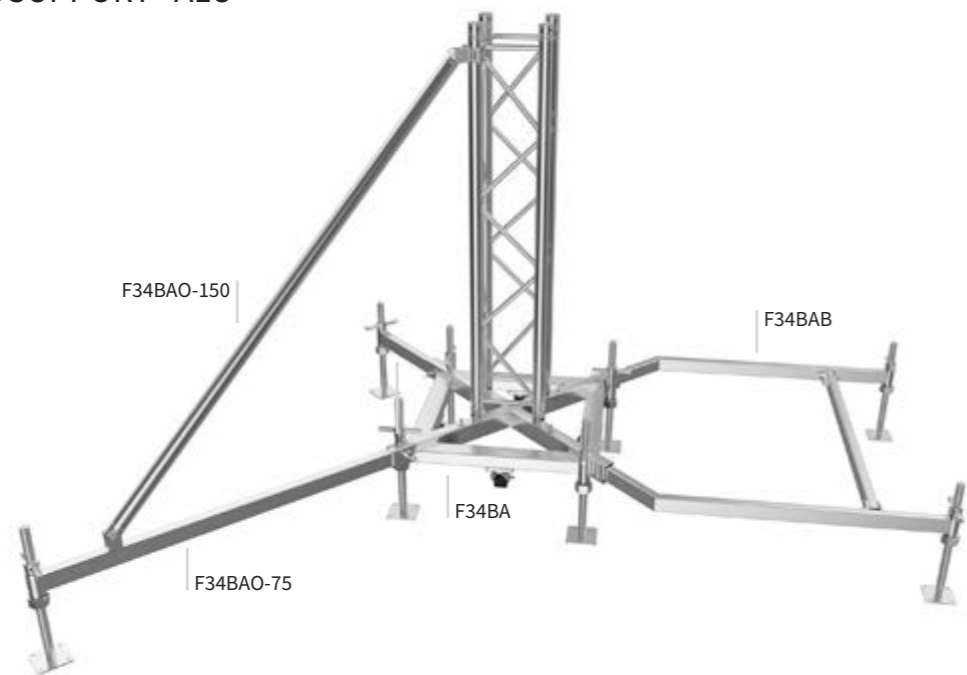

BASE
für F-34/F-44
mit Rollen/FüÙe Alu
for F-34/F-44 with wheels/feet Alu
CODE F34BA

OUTRIGGER BASE
Outrigger Base
New Style 75cm Alu
Outrigger Base New Style 75cm ALU
CODE F34BAO-75

AUSLEGEARM
Auslegearm+Querverstrebung
New Style Alu
Outrigger for Ballast New Style Alu
CODE F34BAO-150

OUTRIGGER
Outrigger für Ballast
New Style Alu
Outrigger for Ballast New Style Alu
CODE F34BAB

GROUNDSUPPORT "STAHL"

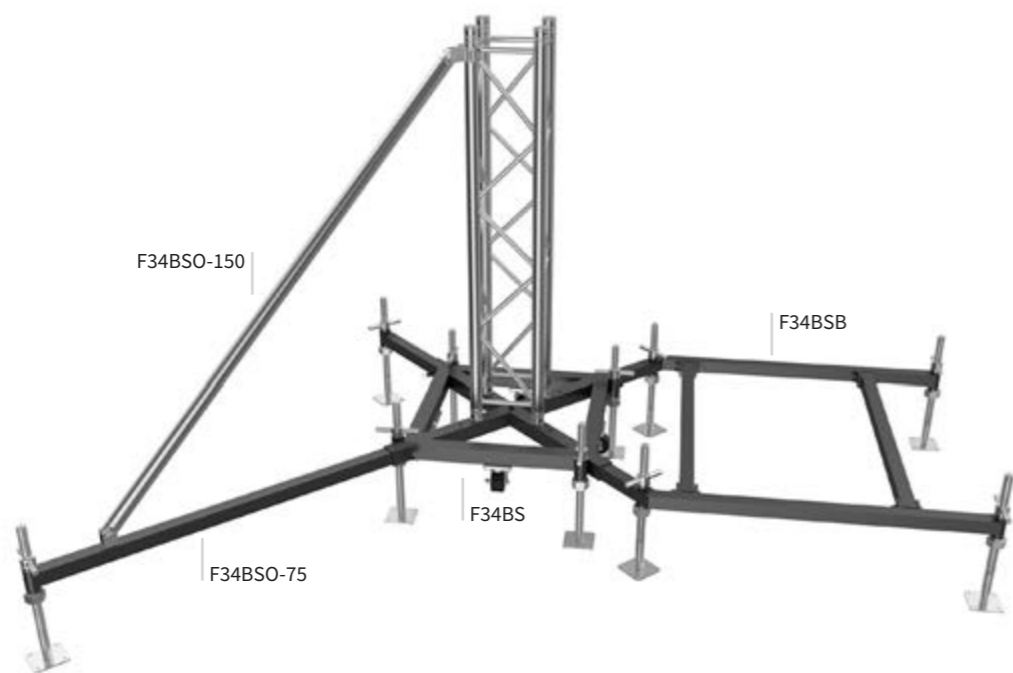

BASE
für F-34/F-44
mit Rollen/FüÙe Stahl
for F-34/F-44 with wheels/feet steel
CODE F34BS

OUTRIGGER
Outrigger Base
New Style 75cm Stahl
Outrigger Base New Style 75cm steel
CODE F34BSO-75

OUTRIGGER + QUERVERSTREBUNG
Auslegearm+Querverstrebung
New Style 150cm Stahl
Outrigger for Ballast New Style 150cm steel
CODE F34BSO-150

OUTRIGGER
Outrigger für Ballast MKII
New Style Stahl
Outrigger for Ballast MKII
New Style steel
CODE F34BSB2

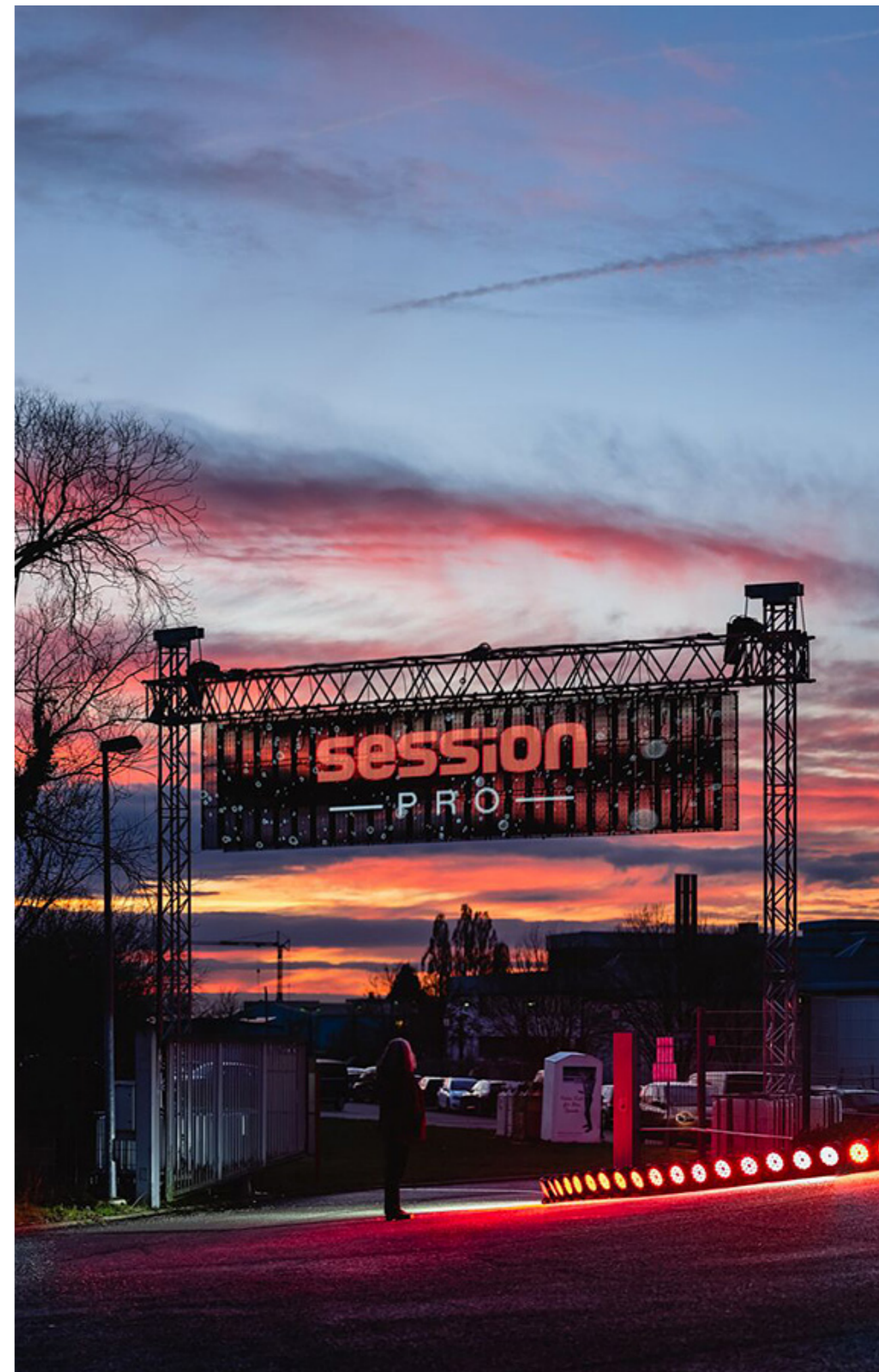

TOWER LIFT



F34 TOWER LIFT

CODE 115277

Der Global Truss Tower Lift für F34 Tower ist eine Hilfe zur Aufrichtung Ihrer Tower. Diese wird einfach auf den Sleeveblock (F34SLEEVE) aufgesteckt und an einer Quertraverse (F34) mit passenden Couplern befestigt. Über die Rolle der Aufrichthilfe können Sie den Kettenzug umlenken und den Tower aufrichten.

Eigenschaften:

- Schnelles und sicheres Aufrichten der Tower
- Passend für F34 Tower
- einfache Anbringung

F44 TOWER LIFT

CODE 115278

Der Global Truss Tower Lift für F44 Tower ist eine Hilfe zur Aufrichtung Ihrer Tower. Diese wird einfach auf den Sleeveblock (F44SLEEVE) aufgesteckt und an einer Quertraverse (F44) mit passenden Couplern befestigt. Über die Rolle der Aufrichthilfe können Sie den Kettenzug umlenken und den Tower aufrichten.

Eigenschaften:

- Schnelles und sicheres Aufrichten der Tower
- Passend für F44 Tower
- einfache Anbringung

The Global Truss Tower Lift for F34 tower is a lifting support for your towers. The tower lift is placed on the sleeve block and fixed with couplers on the horizontal truss (F34). The chain hoist can be redirected through the roll of the lifting tool to lift up the tower.

Features:

- fast and secured lifting of the tower
- works with F34 towers
- easy installation

The Global Truss Tower Lift for F44 tower is a lifting support for your towers. The tower lift is placed on the sleeve block and fixed with couplers on the horizontal truss (F44). The chain hoist can be redirected through the roll of the lifting tool to lift up the tower.

Features:

- fast and secured lifting of the tower
- works with F44 towers
- easy installation



BABY TOWER



Einsatzgebiet: Spezieller Tower für Messe- und TV Anwendung - er zeichnet sich durch sein Design und geringes Transportvolumen aus.

Innovative und kreative Aspekte des Produktes: der F34 Babytower ist unauffällig und kann von der TV Kamera fast nicht wahr genommen werden, bisher war es unmöglich ein Rigg im TV Bereich zu stellen, ohne dass der Fernsehzuschauer es auch sehen konnte.

Der F34 Babytower bringt hier durch seine innovative Formgebung Abhilfe. Verringerung des Transportvolumens um 80%, durch Part in Part Technologie. Der F34 Babytower kann durch Designfolien dem Bühnenbild, der Umgebung oder dem Design des Messestandes angeglichen werden.

Operational area: Special Tower for exhibition and TV use - he is characterizes by: Design, transport volume and is invisible by a TV camera. Innovative and creative aspects: the F34 Baby Tower is unobtrusive and is nearly invisible for TV cameras. He reduces the transport volume about 80 %, through his Part in Part Technology.

Through its Designfoils the F34 Babytower could be very good aligned with stage settings, surrounding areas or the design of exhibition stands. The information is valid for the load-load capacity of a baby Tower independently of the hoist!

The regulations BGV D8 and BGV C1 have to be kept in mind. The Babytower - rigg is for applications, where locations are difficult to accessible, complex to create and even optical unremarkable, which is normal Ground-Support too heavy and too big.

Einrohr-Tower
engineered by Camco
Patent by Karsten Gierß
Single tube tower engineered by Camco
Patent by Karsten Gierß

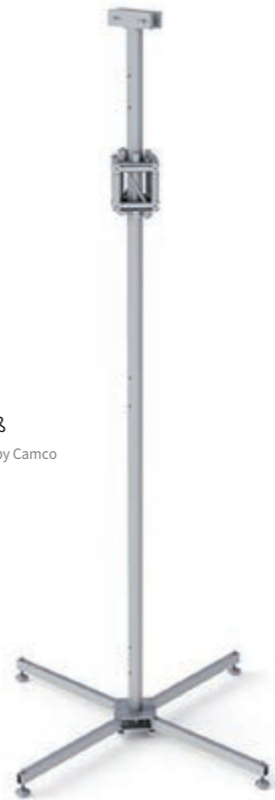

TOWERSEGMENT
TOWER SEGMENT
CODE F34BT100 1m
CODE F34BT200 2m
CODE F34BT300 3m



VERBINDER SPIELFREI
CONNECTOR
Patent and Design by Karsten Gierß
CODE F34BTV



HEADSECTION RIGGING
CODE F34BTRIG



BASEMENT
CODE F34BTBASE



OUTRIGGER MIT SPINDEL
OUTRIGGER WITH SPINDLE
CODE F34BTOUT 1m



SLEEVEBLOCK
CODE F34BTSLEEVE



JUNIOR TOWER



Junior Tower mit LSC-FR Sleeve Block und LSC-FR-JT Rahmen Höhe 8 m

Junior Tower with LSC-FR sleeve block and LSC-FR-JT frame height 8 mtr



Junior Tower mit MSC Sleeve Block Höhe 8 m

Junior Tower height 8 mtr

VERBINDUNGSSTÜCK CONNECTOR JOINT



Due to the connector pieces a seamless connection of the outer tubes is possible. With the pressure piece, the connector profile is spread and connected without seam on the outer tube. The screws are tightened through holes in the outer tube.

Durch die Verbindungsstücke wird eine nahezu spielfreie Verbindung der Außenrohre möglich. Mit dem Druckstück wird das Verbindeprofil gespreizt und legt sich spielfrei an das Außenrohr an. Das Anziehen der Schrauben erfolgt durch Bohrungen im Außenrohr.

ÜBERSICHT DER BAUTEILE | OVERVIEW OF COMPONENTS

 JT-Head	 LSC-FR-JT	 JT-HINGE-M	 JT-M-TYP-M	 JT-BASE
 LSC-FR	 MSC-JT	 LSC-FR + 2 x LSC-FR-JT	 JT-Mast-500 JT-Mast-1000 JT-Mast-1500 JT-Mast-2000 JT-Mast-3000	
 JT-M-TYP-F	 JT-HINGE	 JT-BASE-290	 JT-CON	 MTB

DON'T RIG SHIT.



DATA SHEETS 	SOCIAL MEDIA 	TRUSSTOOL 	TOOLBOX APP 	TRUSS ACADEMY 
--	---	--	--	--

WWW.GLOBALTRUSS.DE

F42

Das F42 Traversensystem von Global Truss ist ein TÜV-geprüftes 2-Punkt System mit einem Außenmaß von 40cm. Konstruktionen im Verbund als Rasterdecke (Grid) für Messestände und Festinstallationen lassen sich mit diesem System ideal realisieren. Auskragungen und Querstrecken mit geringer Belastung sind ebenso möglich. Im Gridverbund sind so Spannweiten bis 10m möglich.

Die F42 Traverse ist aus 50x2mm Gurtrohren und 25x3mm Diagonalbracings aus Aluminium gefertigt. Verbunden werden die Traversen mit konischen Verbindern, welche im Lieferumfang enthalten sind. Wie alle Global Truss Traversen lässt sich auch diese in beliebigen Farben pulverbeschichten.

The F42 truss series by Global Truss is a TÜV approved 2-point system with an external dimension of 40cm. Grid constructions for exhibition stands or permanent installations can be perfectly created with this system. Short outrigs or cross ways with little loads can also be created. As a grid a maximum span of up to 10 meters can be used.

The F42 truss is built with 50 x 2mm main tubes and 25 x 3mm diagonal braces of aluminium. The truss pieces are connected with the included conical connectors. This truss and all other Global Truss series can be powder coated in every RAL colour.



TECHNISCHE DATEN

Rohrdurchmesser Hauptrohr: 50 mm
 Wandstärke: 2,0 mm
 Material: Al EN AW-6082 T6
 Rohrdurchmesser Brace: 25 mm
 Konische Verbinder: enthalten

TECHNICAL DATA

Pipe diameter: 50 mm
 Wall thickness: 2,0 mm
 Material: Al EN AW-6082 T6
 Brace diameter: 25 mm
 Connectors: included



GERADEN | STRAIGHTS

CODE	Länge length	Gewicht weight
F42050	50 cm	1,7 kg
F42100	100 cm	2,5 kg
F42150	150 cm	3,5 kg
F42200	200 cm	4,6 kg
F42250	250 cm	5,7 kg
F42300	300 cm	6,7 kg
F42350	350 cm	7,8 kg
F42400	400 cm	8,6 kg
F42450	450 cm	9,9 kg
F42500	500 cm	10,9 kg



BODENPLATTE | BASE PLATE CODE F42BASE



1,0 kg 60 50 420

45° ECKE | CORNER C19 H CODE F42C19H



7,0 kg 50 1000 1000

45° ECKE | CORNER C19 V CODE F42C19V



7,0 kg 400 1000 1000

60° ECKE | CORNER C20 H CODE F42C20H

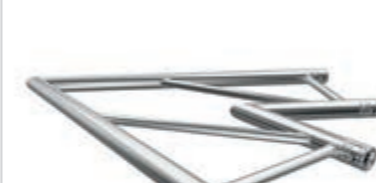

7,0 kg 50 1000 1000

60° ECKE | CORNER C20 V CODE F42C20V



7,0 kg 400 1000 1000

90° ECKE | CORNER C21 H CODE F42C21H



4,0 kg 50 500 500

LOAD TABLE

Span	Uniform distribution load		Center point load		point load in third-point	
	kg / m	Deflection cm	kg	Deflection cm	kg	Deflection cm
2,00	832,00	0,13	954,00	0,12	580,00	0,13
3,00	554,00	0,45	746,00	0,32	476,00	0,35
4,00	321,00	0,83	610,00	0,63	401,00	0,70
5,00	205,00	1,29	511,00	1,04	346,00	1,19
6,00	141,00	1,86	424,00	1,49	303,00	1,81
7,00	103,00	2,53	361,00	2,04	269,00	2,57
8,00	79,00	3,31	314,00	2,67	236,00	3,38
9,00	62,00	4,19	277,00	3,39	208,00	4,28
10,00	49,00	5,18	247,00	4,20	185,00	5,29

Span	Uniform distribution load		Center point load		point load in third-point	
	kg / m	cm	kg	cm	kg	cm
2,00	832,00	0,13	860,00	0,11	580,00	0,13
3,00	381,00	0,31	572,00	0,25	429,00	0,32
4,00	213,00	0,55	427,00	0,44	320,00	0,56
5,00	136,00	0,86	339,00	0,69	255,00	0,88
6,00	94,00	1,24	281,00	1,00	211,00	1,27
7,00	68,00	1,69	239,00	1,37	179,00	1,73
8,00	52,00	2,21	207,00	1,79	155,00	2,26
9,00	40,00	2,80	182,00	2,28	136,00	2,86
10,00	32,00	3,47	161,00	2,82	121,00	3,54

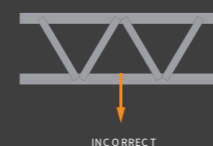
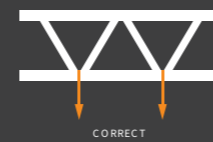

(*) values only valid if the load burdens the junction

Compression chord held every 1.0m!

Das Eigengewicht der Traverse ist in der Belastungstabelle berücksichtigt.
 The dead load of the truss is considered in the load table.

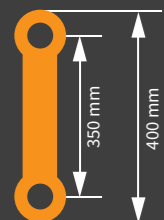

90° ECKE | CORNER C21 V
CODE F42C21V



4,0 kg 500 400 500

120° ECKE | CORNER C22 H
CODE F42C22H



4,0 kg 500 50 500

120° ECKE | CORNER C22 V
CODE F42C22V



4,0 kg 500 400 500

90° ECKE | CORNER C31 V
CODE F42C31V



6,0 kg 500 500 500

X-STÜCK | JOINT C41 H
CODE F42C41H



6,0 kg 500 50 500

X-STÜCK | JOINT C41V
CODE F42C41V



6,0 kg 500 390 500

135° ECKE | CORNER C23 H
CODE F42C23H



4,0 kg 500 50 500

135° ECKE | CORNER C23 V
CODE F42C23V



4,0 kg 500 400 500

90° ECKE | CORNER C31 H
CODE F42C31H



6,0 kg 500 500 500

T-STÜCK | JOINT T35 H
CODE F42T35H



5,5 kg 500 50 500

T-STÜCK | JOINT T35 V
CODE F42T35V



5,5 kg 500 400 500

T-STÜCK | JOINT T42 H
CODE F42T42H



6,0 kg 500 500 500

T-STÜCK | JOINT T42V
CODE F42T42V



6,0 kg 500 500 500



Zubehör/Accessories

VERBINDER SET
CONNECTOR SET
Konus, Bolzen & R-Clip
cone, pin and r-clip.
CODE 5002



ADAPTERKONUS
CONICAL ADAPTER
Konus F32 auf F34
cone F32 to F34
CODE F3432L links/left
CODE F3432R rechts/right



BOLZEN & R-CLIP
PIN & R-CLIP
CODE 5004



BOLZEN | PIN
Bolzen mit M8 Gewinde
pin with M8 thread
CODE 5005



F43



Das F43 Traversensystem von Global Truss ist ein TÜV-geprüftes 3-Punkt System mit einem Außenmaß von 40cm. Mit diesem System werden Einzelstrecken aber auch komplexere Bauten mit höheren Lasten realisiert. Ausgelegt ist dieses Traversensystem für eine Spannweite bis zu 18m.

Die F43 Traverse ist aus 50x2mm Gurtrohren und 25x3mm Diagonalbracings aus Aluminium gefertigt. Verbunden werden die Traversen mit konischen Verbindern, welche im Lieferumfang enthalten sind. Wie alle Global Truss Traversen lässt sich auch diese in beliebigen Farben pulverbeschichten.

The F43 truss series by Global Truss is a TÜV approved 3-point system with an external dimension of 40cm. This system is used for single truss lines as well as complex constructions with greater loads. A maximum span of up to 18 meters can be created with this system.

The F43 truss is built with 50 x 2mm main tubes and 25 x 3mm diagonal braces of aluminium. The truss pieces are connected with the included conical connectors. This truss and all other Global Truss series can be powder coated in every RAL colour.



TECHNISCHE DATEN

Rohrdurchmesser Hauptrohr: 50 mm
 Wandstärke: 2,0 mm
 Material: Al EN AW-6082 T6
 Rohrdurchmesser Brace: 25 mm
 Konische Verbinder: enthalten

TECHNICAL DATA

Pipe diameter: 50 mm
 Wall thickness: 2,0 mm
 Material: Al EN AW-6082 T6
 Brace diameter: 25 mm
 Connectors: included

GERADEN | STRAIGHTS

CODE	Länge length	Gewicht weight
F43050	50 cm	4,9 kg
F43100	100 cm	7,5 kg
F43150	150 cm	9,7 kg
F43200	200 cm	12,0 kg
F43250	250 cm	14,0 kg
F43300	300 cm	16,0 kg
F43350	350 cm	19,0 kg
F43400	400 cm	21,0 kg
F43450	450 cm	23,6 kg
F43500	500 cm	25,9 kg



LOAD TABLE

Span	Uniform distribution load		Center point load		Point load in third-point		Point load in quarter-point		Point load in fifth-point	
	kg / m	Deflection	kg	Deflection	kg	Deflection	kg	Deflection	kg	Deflection
m	kg / m	cm	kg	cm	kg	cm	kg	cm	kg	cm
4,00	339,00	0,88	604,00	0,63	419,00	0,74	325,00	0,80	256,00	0,80
5,00	219,00	1,40	494,00	1,02	348,00	1,22	262,00	1,28	209,00	1,29
6,00	152,00	2,03	416,00	1,51	296,00	1,81	219,00	1,86	176,00	1,90
7,00	111,00	2,78	358,00	2,09	256,00	2,53	187,00	2,56	151,00	2,63
8,00	84,00	3,65	312,00	2,78	225,00	3,37	162,00	3,38	131,00	3,48
9,00	65,00	4,64	275,00	3,58	200,00	4,33	142,00	4,31	116,00	4,45
10,00	52,00	5,75	244,00	4,48	178,00	5,42	126,00	5,36	103,00	5,54
11,00	42,00	6,98	218,00	5,50	160,00	6,65	113,00	6,53	92,00	6,76
12,00	34,00	8,34	196,00	6,63	145,00	8,01	101,00	7,82	83,00	8,11
13,00	29,00	9,82	177,00	7,89	131,00	9,51	91,00	9,24	75,00	9,59
14,00	24,00	11,43	160,00	9,27	119,00	11,14	82,00	10,79	68,00	11,20
15,00	20,00	13,16	145,00	10,79	108,00	12,93	74,00	12,47	61,00	12,94
16,00	17,00	15,03	131,00	12,45	99,00	14,86	67,00	14,28	55,00	14,83
17,00	15,00	17,03	119,00	14,26	90,00	16,95	61,00	16,22	50,00	16,85
18,00	12,00	19,16	107,00	16,22	82,00	19,20	55,00	18,31	45,00	19,02

Das Eigengewicht der Traverse ist in der Belastungstabelle berücksichtigt.
 The dead load of the truss is considered in the load table.

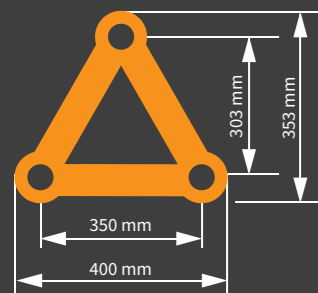

BODENPLATTE | BASE PLATE CODE F43BASE



2,0 kg
 60
 400 400

45° ECKE | CORNER C19 CODE F43C19



8,97 kg
 353
 1000 1000

60° ECKE | CORNER C20 CODE F43C20



6,0 kg
 353
 1000 1000

90° ECKE | CORNER C21 CODE F43C21



5,28 kg
 353
 500 500

120° ECKE | CORNER C22 CODE F43C22



6,58 kg
 353
 500 500

135° ECKE | CORNER C23 CODE F43C23



6,71 kg
 353
 500 500

90° ECKE | CORNER C24
CODE F43C24



4,7 kg
500 500 400

90° ECKE | CORNER C25
CODE F43C25



5,5 kg
500 500 400

90° ECKE | CORNER C31
CODE F43C31



7,6 kg
500 500 500

T-STÜCK | JOINT T35
CODE F43T35



7,9 kg
500 500 400

T-STÜCK | JOINT T36
CODE F43T36



6,9 kg
500 500 400

T-STÜCK | JOINT T37
CODE F43T37



6,9 kg
500 500 400

90° ECKE | CORNER C32
CODE F43C32



7,6 kg
500 500 500

90° ECKE | CORNER C33
CODE F43C33



8,1 kg
500 500 500

90° ECKE | CORNER C34
CODE F43C34



8,1 kg
500 500 500

T-STÜCK | JOINT T38
CODE F43T38



7,4 kg
500 500 400

T-STÜCK | JOINT T39
CODE F43T39



7,2 kg
500 500 400

T-STÜCK | JOINT T42
CODE F43T42



9,1 kg
500 500 500

X-STÜCK | JOINT C41
CODE F43C41



7,5 kg
500 500 400

90° ECKE | CORNER C44
CODE F43C44



9,4 kg
500 500 500

90° ECKE | CORNER C45
CODE F43C45



9,2 kg
500 500 500

T-STÜCK | JOINT T43
CODE F43T43



8,4 kg
500 500 500

4-WEG STÜCK | JOINT T47
CODE F43T47



8,7 kg
500 500 500

T-STÜCK | JOINT T51
CODE F43T51



10,7 kg
500 500 500

X-STÜCK | JOINT C52
CODE F43C52



9,7 kg
500 500 500

X-STÜCK | JOINT C53
CODE F43C53



10,1 kg
500 500 500

X-STÜCK | JOINT C61
CODE F43C61



11,3 kg
500 500 500

Zubehör/Accessories

VERBINDER SET
CONNECTOR SET
Konus, Bolzen & R-Clip
cone, pin and r-clip.
CODE 5002



KONUS | CONE
Konus für F32-44
cone for F32-F44
CODE 5009



BOLZEN & R-CLIP
PIN & R-CLIP
CODE 5004



BOLZEN | PIN
Bolzen mit M8 Gewinde
pin with M8 thread
CODE 5005



F44



Das F44 Traversensystem von Global Truss ist ein TÜV-geprüftes 4-Punkt System mit einem Außenmaß von 40cm. Die F44 bietet herausragende Belastungseigenschaften und eine geringe Durchbiegung. Ihren Einsatz findet diese Traverse bei Bauten mit hohen Traglasten, größeren Bühnensystemen oder Festinstallationen. Ausgelegt ist dieses Traversensystem für eine Spannweite bis zu 20m.

Die F44 Traverse ist aus 50x2mm Gurtrohren und 25x3mm Diagonalbracings aus Aluminium gefertigt. Verbunden werden die Traversen mit konischen Verbindern, welche im Lieferumfang enthalten sind. Wie alle Global Truss Traversen lässt sich auch diese in beliebigen Farben pulverbeschichten.

The F44 truss series by Global Truss is a TÜV approved 4-point system with an external dimension of 40cm. The system offers an outstanding load capacity and low deflection, ideal for complex constructions with high loads, along with stage systems and permanent installations. A maximum span of up to 20 meters can be created with this system.

The F44 truss is built with 50 x 2mm main tubes and 25 x 3mm diagonal braces of aluminium. The truss pieces are connected with the included conical connectors. This truss and all other Global Truss series can be powder coated in every RAL colour.

TECHNISCHE DATEN

Rohrdurchmesser Hauptrohr:	50 mm
Wandstärke:	2,0 mm
Material:	Al EN AW-6082 T6
Rohrdurchmesser Brace:	25 mm
Konische Verbinder	enthalten

TECHNICAL DATA

Pipe diameter:	50 mm
Wall thickness:	2,0 mm
Material:	Al EN AW-6082 T6
Brace diameter:	25 mm
Connectors	included



GERADEN | STRAIGHTS

CODE	Länge length	Gewicht weight
F44025	25 cm	3,5 kg
F44050	50 cm	5,5 kg
F44100	100 cm	8,4 kg
F44150	150 cm	10,9 kg
F44200	200 cm	13,4 kg
F44250	250 cm	15,7 kg
F44300	300 cm	17,9 kg
F44350	350 cm	21,3 kg
F44400	400 cm	23,5 kg
F44450	450 cm	26,4 kg
F44500	500 cm	29,0 kg



LOAD TABLE

Das Eigengewicht der Traverse ist in der Belastungstabelle berücksichtigt.
The dead load of the truss is considered in the load table.

Span	Uniform distribution load		Center point load		Point load in third-point		Point load in quarter-point		Point load in fifth-point	
	kg / m	cm	kg	cm	kg	cm	kg	cm	kg	cm
4,00	716,00	0,92	1232,00	0,64	809,00	0,71	611,00	0,75	517,00	0,81
5,00	481,00	1,52	1037,00	1,06	696,00	1,20	540,00	1,30	444,00	1,36
6,00	342,00	2,25	893,00	1,58	609,00	1,83	483,00	2,02	380,00	2,03
7,00	254,00	3,12	782,00	2,22	540,00	2,60	424,00	2,83	332,00	2,83
8,00	195,00	4,12	694,00	2,97	484,00	3,50	372,00	3,75	294,00	3,77
9,00	154,00	5,26	622,00	3,83	437,00	4,54	332,00	4,79	263,00	4,85
10,00	125,00	6,54	562,00	4,81	398,00	5,73	298,00	5,97	238,00	6,06
11,00	102,00	7,95	512,00	5,91	364,00	7,06	270,00	7,28	216,00	7,42
12,00	85,00	9,50	468,00	7,13	335,00	8,53	246,00	8,73	198,00	8,92
13,00	72,00	11,19	430,00	8,47	309,00	10,15	225,00	10,31	182,00	10,56
14,00	61,00	13,02	397,00	9,94	286,00	11,92	207,00	12,03	168,00	12,34
15,00	53,00	14,99	367,00	11,54	266,00	13,84	191,00	13,89	155,00	14,27
16,00	46,00	17,10	341,00	13,27	248,00	15,91	177,00	15,89	144,00	16,35
17,00	40,00	19,35	317,00	15,14	231,00	18,14	165,00	18,03	134,00	18,58
18,00	35,00	21,75	295,00	17,15	216,00	20,53	153,00	20,32	125,00	20,95
19,00	31,00	24,29	275,00	19,30	202,00	23,08	142,00	22,75	116,00	23,48
20,00	27,00	26,98	257,00	21,61	189,00	25,79	133,00	25,33	109,00	26,16

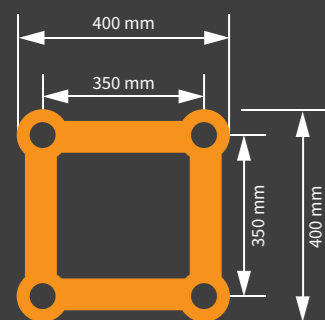

BODENPLATTE | BASE PLATE CODE F44BASE



MULTIBOX MIT 8 VERBINDERN MULTIBOX WITH 8 CONNECTORS CODE F44MULTIBOX M12 Gewinde / M12 thread

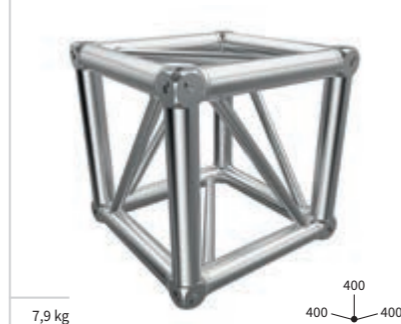

90° ECKE | CORNER C21 CODE CODE F44C21

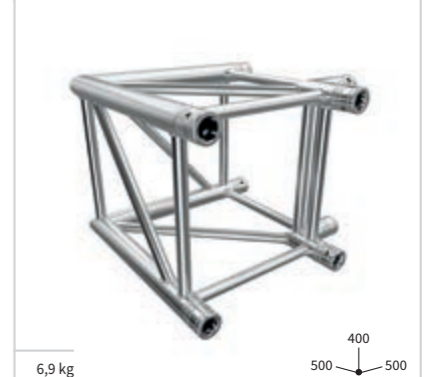

120° ECKE | CORNER C22
CODE F44C22

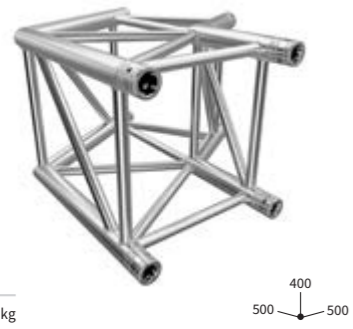

6,8 kg 400
500 ↙ ↘ 500

135° ECKE | CORNER C23
CODE F44C23



9,0 kg 400
500 ↙ ↘ 500

90° ECKE | CORNER C30
CODE F44C30



11,7 kg 500
500 ↙ ↘ 500

X-STÜCK | JOINT C41
CODE F44C41



10,8 kg 400
500 ↙ ↘ 500

X-STÜCK | JOINT C55
CODE F44C55



11,7 kg 500
500 ↙ ↘ 500

T-STÜCK | JOINT T55
CODE F44T5



8,6 kg 400
500 ↙ ↘ 500

T-STÜCK | JOINT T40
CODE F44T40



10,3 kg 500
500 ↙ ↘ 500

THE
• TRUSS •
ACADEMY
Global Truss
www.TRUSSACADEMY.com



F44P



Das F44P Traversensystem von Global Truss ist ein TÜV-geprüftes 4-Punkt System mit einem Außenmaß von 40cm. Die F44P bietet herausragende Belastungseigenschaften und eine geringe Durchbiegung. Ihren Einsatz findet diese Traverse bei Bauten mit hohen Traglasten, größeren Bühnensystemen oder Festinstallationen. Die Eigenschaften dieser Traverse sind ideal für Tower-Anwendungen im Schwerlastbereich. Durch die Erhöhung der Gurtrohrwandstärke sind höhere Lasten gegenüber der F44 Traverse möglich, wobei beide Systeme miteinander kombinierbar sind. Ausgelegt ist dieses Traversensystem für eine Spannweite bis zu 20m.

Die F44P Traverse ist aus 50x3mm Gurtrohren und 25x3mm Diagonalbracings aus Aluminium gefertigt. Verbunden werden die Traversen mit konischen Verbindern, welche im Lieferumfang enthalten sind. Wie alle Global Truss Traversen lässt sich auch diese in beliebigen Farben pulverbeschichten.

The F44P truss series by Global Truss is a TÜV approved 4-point system with an external dimension of 40cm. The system offers an outstanding load capacity and low deflection, ideal for complex constructions with high loads, along with stage systems and permanent installations. The characteristics of this truss is perfect for heavy duty tower applications. Due to the higher main tube wall thickness even greater loads can be supported than with the F44 are possible. Nevertheless both systems are compatible with each other. A maximum span of up to 20 meters can be created with this system.

The F44P truss is built with 50 x 3mm main tubes and 25 x 3mm diagonal braces of aluminium. The truss pieces are connected with the included conical connectors. This truss and all other Global Truss series can be powder coated in every RAL colour.

TECHNISCHE DATEN

Rohrdurchmesser Hauptrohr:	50 mm
Wandstärke:	3,0 mm
Material:	Al EN AW-6082 T6
Rohrdurchmesser Brace:	25 mm
Konische Verbinder	enthalten

TECHNICAL DATA

Pipe diameter:	50 mm
Wall thickness:	3,0 mm
Material:	Al EN AW-6082 T6
Brace diameter:	25 mm
Connectors	included

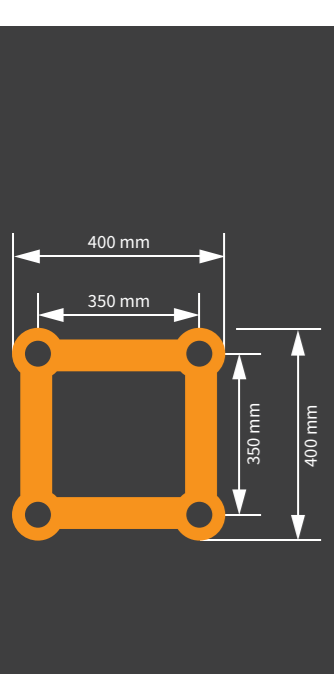

LOAD TABLE

Span	Uniform distribution load	Deflection	Center point load	Deflection	Point load in third-point	Deflection	Point load in quarter-point	Deflection	Point load in fifth-point	Deflection
m	kg / m	cm	kg	cm	kg	cm	kg	cm	kg	cm
4,00	942,00	0,83	1801,00	0,63	1180,00	0,71	888,00	0,74	757,00	0,80
5,00	706,00	1,51	1520,00	1,05	1018,00	1,19	787,00	1,29	650,00	1,35
6,00	503,00	2,25	1311,00	1,57	893,00	1,82	706,00	2,00	559,00	2,02
7,00	374,00	3,11	1151,00	2,21	793,00	2,58	624,00	2,82	489,00	2,82
8,00	288,00	4,12	1023,00	2,95	712,00	3,48	549,00	3,74	433,00	3,75
9,00	228,00	5,25	919,00	3,81	644,00	4,52	490,00	4,78	389,00	4,83
10,00	185,00	6,53	832,00	4,78	588,00	5,70	441,00	5,95	352,00	6,04
11,00	152,00	7,94	759,00	5,87	539,00	7,02	401,00	7,26	321,00	7,39
12,00	127,00	9,48	697,00	7,07	497,00	8,48	366,00	8,69	294,00	8,88
13,00	108,00	11,17	642,00	8,40	460,00	10,09	336,00	10,27	271,00	10,51
14,00	92,00	12,99	594,00	9,84	427,00	11,84	310,00	11,97	251,00	12,28
15,00	79,00	14,95	552,00	11,41	398,00	13,74	288,00	13,82	233,00	14,20
16,00	69,00	17,05	514,00	13,11	372,00	15,79	267,00	15,80	217,00	16,26
17,00	60,00	19,29	480,00	14,94	349,00	17,99	249,00	17,92	202,00	18,46
18,00	53,00	21,67	449,00	16,90	327,00	20,34	233,00	20,18	189,00	20,82
19,00	47,00	24,20	420,00	19,00	307,00	22,85	218,00	22,59	177,00	23,32
20,00	42,00	26,87	395,00	21,24	289,00	25,52	204,00	25,13	166,00	25,97

Das Eigengewicht der Traverse ist in der Belastungstabelle berücksichtigt.
The dead load of the truss is considered in the load table.

GERADEN | STRAIGHTS

CODE	Länge length	Gewicht weight
F44050P	50 cm	6,5 kg
F44100P	100 cm	9,5 kg
F44150P	150 cm	12,4 kg
F44200P	200 cm	15,8 kg
F44250P	250 cm	18,6 kg
F44300P	300 cm	21,7 kg
F44350P	350 cm	24,6 kg
F44400P	400 cm	27,6 kg
F44450P	450 cm	30,5 kg
F44500P	500 cm	33,9 kg



BODENPLATTE | BASE PLATE P
CODE F44BASE



2,0 kg
400 50 400

90° ECKE | CORNER C21 P
CODE F44C21P



6,9 kg
500 400 500

120° ECKE | CORNER C22 P
CODE F44C22P



6,8 kg
500 400 500

135° ECKE | CORNER C23 P
CODE F44C23P



9,0 kg
500 400 500

90° ECKE | CORNER C30 P
CODE F44C30P



9,4 kg
500 500 500

X-STÜCK | JOINT C41 P
CODE F44C41P



10,8 kg
500 400 500

X-STÜCK | JOINT C55 P
CODE F44C55P



11,7 kg
500 500 500

T-STÜCK | JOINT T35 P
CODE F44T35P



8,6 kg
500 400 500

T-STÜCK | JOINT T40 P
CODE F44T40P



10,3 kg
500 500 500

Zubehör/Accessories

**VERBINDER SET
CONNECTOR SET**
Konus, Bolzen & R-Clip
cone, pin and r-clip.
CODE 5002



KONUS | CONE
Konus für F32-44
cone for F32-F44
CODE 5009



**BOLZEN & R-CLIP
PIN & R-CLIP**
CODE 5004



BOLZEN | PIN
Bolzen mit M8 Gewinde
pin with M8 thread
CODE 5005

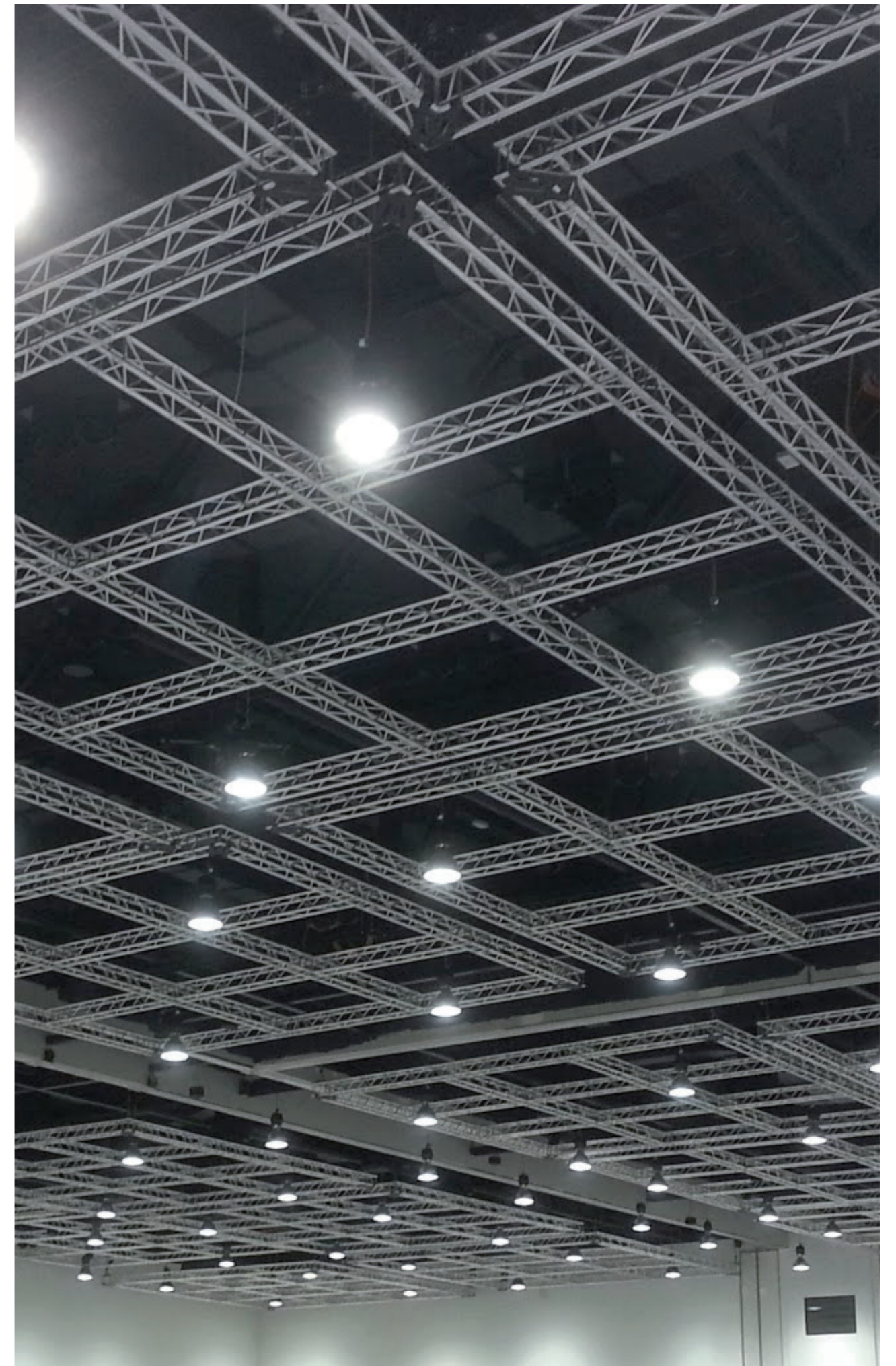

F44P-B



Das F44P Traversensystem von Global Truss ist ein TÜV-geprüftes 4-Punkt System mit einem Außenmaß von 40cm. Die F44P bietet herausragende Belastungseigenschaften und eine geringe Durchbiegung. Ihren Einsatz findet diese Traverse bei Bauten mit hohen Traglasten, größeren Bühnensystemen oder Festinstallationen. Die Eigenschaften dieser Traverse sind ideal für Tower-Anwendungen im Schwerlastbereich. Durch die Erhöhung der Gurtrohrwandstärke sind höhere Lasten gegenüber der F44 Traverse möglich, wobei beide Systeme miteinander kombinierbar sind. Ausgelegt ist dieses Traversensystem für eine Spannweite bis zu 20m.

Die F44P Traverse ist aus 50x3mm Gurtrohren und 25x3mm Diagonalbracings aus Aluminium gefertigt. Verbunden werden die Traversen mit konischen Verbindern, welche im Lieferumfang enthalten sind.

The F44P truss series by Global Truss is a TÜV approved 4-point system with an external dimension of 40cm. The system offers an outstanding load capacity and low deflection, ideal for complex constructions with high loads, along with stage systems and permanent installations. The characteristics of this truss is perfect for heavy duty tower applications. Due to the higher main tube wall thickness even greater loads can be supported than with the F44 are possible. Nevertheless both systems are compatible with each other. A maximum span of up to 20 meters can be created with this system.

The F44P truss is built with 50 x 3mm main tubes and 25 x 3mm diagonal braces of aluminium. The truss pieces are connected with the included conical connectors.

GERADEN | STRAIGHTS BLACK

CODE	Länge length	Gewicht weight
F44025P-B	25 cm	3,5 kg
F44050P-B	50 cm	6,5 kg
F44100P-B	100 cm	9,5 kg
F44200P-B	200 cm	15,8 kg
F44300P-B	300 cm	21,7 kg



TECHNISCHE DATEN

Rohrdurchmesser Hauptrohr:	50 mm
Wandstärke:	3,0 mm
Material:	Al EN AW-6082 T6
Rohrdurchmesser Brace:	25 mm
Konische Verbinder	enthalten

TECHNICAL DATA

Pipe diameter:	50 mm
Wall thickness:	3,0 mm
Material:	Al EN AW-6082 T6
Brace diameter:	25 mm
Connectors	included



BODENPLATTE | BASE PLATE P CODE F44BASE-B



2,0 kg
50
400 400

90° ECKE | CORNER C21 P CODE F44C21P-B



6,9 kg
500 500

90° ECKE | CORNER C30 P CODE F44C30P-B



9,4 kg
500 500

T-STÜCK | JOINT T35 P CODE F44T35P-B



8,6 kg
500 500

T-STÜCK | JOINT T40 P CODE F44T40P-B



10,3 kg
500 500

X-STÜCK | JOINT C41 P CODE F44C41P-B



10,8 kg
500 500

LOAD TABLE

Span	Uniform distribution load		Center point load		Point load in third-point		Point load in quarter-point		Point load in fifth-point	
	kg / m	Deflection cm	kg	Deflection cm	kg	Deflection cm	kg	Deflection cm	kg	Deflection cm
4,00	942,00	0,83	1801,00	0,63	1180,00	0,71	888,00	0,74	757,00	0,80
5,00	706,00	1,51	1520,00	1,05	1018,00	1,19	787,00	1,29	650,00	1,35
6,00	503,00	2,25	1311,00	1,57	893,00	1,82	706,00	2,00	559,00	2,02
7,00	374,00	3,11	1151,00	2,21	793,00	2,58	624,00	2,82	489,00	2,82
8,00	288,00	4,12	1023,00	2,95	712,00	3,48	549,00	3,74	433,00	3,75
9,00	228,00	5,25	919,00	3,81	644,00	4,52	490,00	4,78	389,00	4,83
10,00	185,00	6,53	832,00	4,78	588,00	5,70	441,00	5,95	352,00	6,04
11,00	152,00	7,94	759,00	5,87	539,00	7,02	401,00	7,26	321,00	7,39
12,00	127,00	9,48	697,00	7,07	497,00	8,48	366,00	8,69	294,00	8,88
13,00	108,00	11,17	642,00	8,40	460,00	10,09	336,00	10,27	271,00	10,51
14,00	92,00	12,99	594,00	9,84	427,00	11,84	310,00	11,97	251,00	12,28
15,00	79,00	14,95	552,00	11,41	398,00	13,74	288,00	13,82	233,00	14,20
16,00	69,00	17,05	514,00	13,11	372,00	15,79	267,00	15,80	217,00	16,26
17,00	60,00	19,29	480,00	14,94	349,00	17,99	249,00	17,92	202,00	18,46
18,00	53,00	21,67	449,00	16,90	327,00	20,34	233,00	20,18	189,00	20,82
19,00	47,00	24,20	420,00	19,00	307,00	22,85	218,00	22,59	177,00	23,32
20,00	42,00	26,87	395,00	21,24	289,00	25,52	204,00	25,13	166,00	25,97

Das Eigengewicht der Traverse ist in der Belastungstabelle berücksichtigt.
The dead load of the truss is considered in the load table.

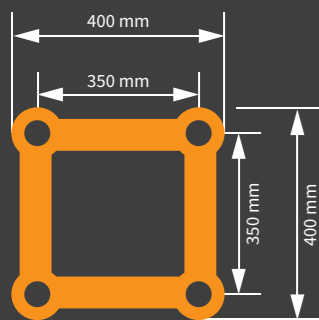

F45



Die F45 Traverse von Global Truss basiert auf der F44P 400mm x 400mm und ist besonders für Anwendungen geeignet bei denen eine zentrierte Aufhängung der LED Leinwand von wesentlicher Bedeutung ist. Auf der Unterseite der Traverse können LED Panels direkt an das mittige Gurtrohr mit Leiterbraces sicher befestigt werden. Dies macht es überflüssig, über die beiden unteren Gurtrohre eine Schlinge zu legen oder diese zu stützen, um einen zentralen Riggingpunkt zu schaffen, wie er normalerweise bei einem quadratischen Träger erforderlich wäre. Des Weiteren schafft das Leiterstil-Bracing mehr freien Hängeraum entlang des Gurtrohrs im Vergleich zu den äußeren Gurten. Da die neue Traverse auf dem F44P Design basiert, lässt sich die F45 mit allen Standard F44P Traversen, auch mit Sleeveblöcken, verbinden und schafft so die Voraussetzung, dass man die neue F45 in bestehende F44P Konstruktionen nahtlos integrieren kann.

This F45 Truss is based on the F44P 400mm x 400mm truss design and is used for applications such as LED screens where balanced centre rigging of the screen panels on the truss is essential. A central chord with ladder-style horizontal bracing on the bottom face of the truss allows LED panels to be clamped directly onto the centre chord. This negates the need to sling or brace across the two bottom chords to provide a central rigging points as would normally be necessary on a square format truss. Furthermore, the ladder-style horizontal braces creates more and more clear hanging space along the chord compared to the outside chords. Because it is based on the F44P Truss design, F45 Truss can connect to all standard F44P junctions or sleeve blocks so you use your existing F44P Truss to build the rest of the structure! Future development of truss accessories will mean that use of F45 Truss will not be limited to LED screen hanging applications.

TECHNISCHE DATEN

Rohrdurchmesser Hauptrohr: 50 mm
 Wandstärke: 4,0 mm
 Material: Al EN AW-6082 T6
 Rohrdurchmesser Brace: 25 mm
 Konische Verbinder: enthalten

TECHNICAL DATA

Pipe diameter: 50 mm
 Wall thickness: 4,0 mm
 Material: Al EN AW-6082 T6
 Brace diameter: 25 mm
 Connectors: included



GERADEN | STRAIGHTS

CODE	Länge length	Gewicht weight
F45050	50 cm	9,6 kg
F45100	100 cm	15,8 kg
F45150	150 cm	22,1 kg
F45200	200 cm	28,4 kg
F45250	250 cm	33,4 kg
F45300	300 cm	39,1 kg



F54



Das F54 Traversensystem von Global Truss ist ein TÜV-geprüftes 4-Punkt-Schwerlast-System mit einem Außenmaß von 52cm. Die hohe Traglast und Spannweite definieren das Einsatzgebiet dieser Traversen. Große Bühnendächer und Ground-Support Konstruktionen mit mehreren Tonnen Belastung sind problemlos möglich. Ausgelegt ist dieses Traversensystem für eine Spannweite bis zu 24m.

Die F54 Traverse ist aus 50x4mm Gurtrohren und 30x3mm Diagonalbracings aus Aluminium gefertigt. Verbunden werden die Traversen mit speziellen konischen Verbindern (60mm), welche im Lieferumfang enthalten sind. Wie alle Global Truss Traversen lässt sich auch diese in beliebigen Farben pulverbeschichten.

The F54 truss series by Global Truss is a TÜV approved 4-point heavy duty system with an external dimension of 52cm. The high load capacity and wide span increases the range of use for this system. Big stage roofs and ground support constructions with tons of load are supported with ease, whilst a maximum span of up to 24 meters can be created.

The F54 truss is built with 50 x 4mm main tubes and 30 x 3 mm diagonal braces of aluminium. The truss pieces are connected with the included special conical connectors (60mm). This truss and all other Global Truss series can be powder coated in every RAL colour.

TECHNISCHE DATEN

Rohrdurchmesser Hauptrohr:	50 mm
Wandstärke:	4,0 mm
Material:	Al EN AW-6082 T6
Rohrdurchmesser Brace:	30 mm
Konische Verbinder	enthalten

TECHNICAL DATA

Pipe diameter:	50 mm
Wall thickness:	4,0 mm
Material:	Al EN AW-6082 T6
Brace diameter:	30 mm
Connectors	included



GERADEN | STRAIGHTS

CODE	Länge length	Gewicht weight
F54050	50 cm	15,3 kg
F54100	100 cm	20,7 kg
F54150	150 cm	26,2 kg
F54200	200 cm	31,6 kg
F54250	250 cm	37,6 kg
F54300	300 cm	46,0 kg
F54350	350 cm	53,8 kg
F54400	400 cm	58,9 kg
F54450	450 cm	66,5 kg
F54500	500 cm	76,8 kg

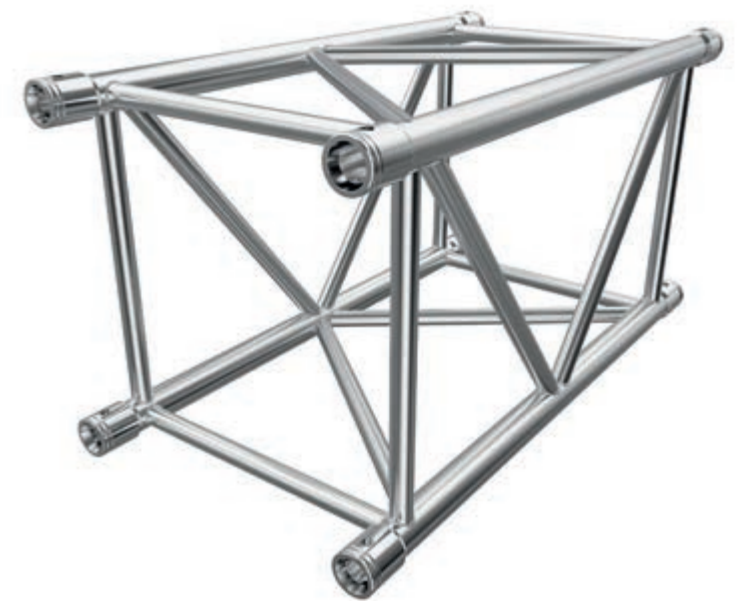

90° ECKE | CORNER C21 CODE F54C21



15,5 kg 520
710 710

X-STÜCK | JOINT C41 CODE F54C41



25,7 kg 520
900 900

T-STÜCK | JOINT T35 CODE F54T35



20,9 kg 520
710 900

BOX CORNER MIT 8 VERBINDERN BOX CORNER WITH 8 CONNEXORS CODE F54BOX



13,3 kg 520
520 520



LOAD TABLE

Das Eigengewicht der Traverse ist in der Belastungstabelle berücksichtigt.
The dead load of the truss is considered in the load table.

Span	Uniform distribution load	Deflection		Center point load		Point load in third-point		Point load in quarter-point		Point load in fifth-point	
		cm	kg	cm	kg	cm	kg	cm	kg	cm	kg
4,00	1255,00	0,47	2641,00	0,40	1628,00	0,42	1191,00	0,43	977,00	0,44	820,00
5,00	1001,00	0,92	2290,00	0,68	1453,00	0,73	1065,00	0,75	890,00	0,80	742,00
6,00	783,00	1,50	2015,00	1,04	1304,00	1,14	977,00	1,19	820,00	1,27	692,00
7,00	601,00	2,15	1794,00	1,48	1180,00	1,65	901,00	1,76	764,00	1,89	625,00
8,00	472,00	2,90	1612,00	2,01	1074,00	2,27	835,00	2,45	692,00	2,58	589,00
9,00	378,00	3,75	1461,00	2,62	983,00	2,99	777,00	3,27	625,00	3,35	520,00
10,00	308,00	4,70	1332,00	3,32	905,00	3,81	724,00	4,22	569,00	4,22	478,00
11,00	255,00	5,76	1221,00	4,11	836,00	4,74	668,00	5,24	520,00	5,20	442,00
12,00	214,00	6,92	1124,00	4,99	775,00	5,77	611,00	6,30	478,00	6,28	409,00
13,00	182,00	8,18	1039,00	5,96	721,00	6,92	562,00	7,46	442,00	7,47	380,00
14,00	155,00	9,54	963,00	7,02	672,00	8,17	518,00	8,73	409,00	8,77	354,00
15,00	134,00	10,99	895,00	8,18	628,00	9,54	480,00	10,10	380,00	10,17	330,00
16,00	116,00	12,53	834,00	9,45	587,00	11,03	446,00	11,57	354,00	11,69	309,00
17,00	101,00	14,16	779,00	10,81	551,00	12,63	415,00	13,16	330,00	13,32	289,00
18,00	89,00	15,91	728,00	12,28	517,00	14,35	386,00	14,85	309,00	15,06	270,00
19,00	78,00	17,75	681,00	13,86	486,00	16,19	361,00	16,65	289,00	16,91	253,00
20,00	69,00	19,71	638,00	15,55	457,00	18,16	337,00	18,56	270,00	18,88	237,00
21,00	61,00	21,77	598,00	17,36	430,00	20,25	315,00	20,59	253,00	20,97	223,00
22,00	54,00	23,94	561,00	19,29	405,00	22,47	295,00	22,73	237,00	23,17	213,00
23,00	49,00	26,22	526,00	21,34	381,00	24,82	276,00	24,99	223,00	25,49	209,00
24,00	43,00	28,61	493,00	23,52	359,00	27,30	258,00	27,37	209,00	27,94	200,00

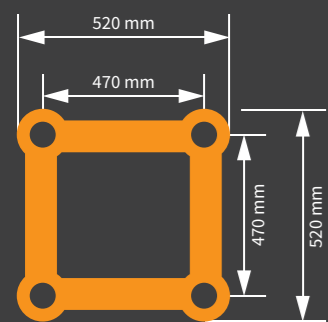

F52



Das F52 Traversensystem von Global Truss ist ein TÜV-geprüftes 4-Punkt Schwerlast-System mit einem Außenmaß von 62cm. Das faltbare Traversensystem wurde speziell für den mobilen Einsatz mit großen Spannweiten und hohen Traglasten konzipiert. Durch das Zusammenklappen der Traverse verringert sich das Transportvolumen um mehr als 50%. Ausgelegt ist dieses Traversensystem für eine Spannweite bis zu 24m.

Die F52 Traverse ist aus 50x4mm Gurtrohren und 25x3mm Diagonalbracings aus Aluminium gefertigt. Verbunden werden die Traversen mit speziellen konischen Verbindern (60mm), welche im Lieferumfang enthalten sind. Wie alle Global Truss Traversen lässt sich auch diese in beliebigen Farben pulverbeschichten.

The F52 truss series by Global Truss is a TÜV approved 4-point heavy duty system with an external dimension of 62cm. This foldable truss system was built for mobile use with large spans and high loads. When folded the transportation volume is reduced by 50%. A maximum span of up to 24 meters can be created with this system.

The F52 truss is built with 50 x 4mm main tubes and 30 x 3mm diagonal braces of aluminium. The truss pieces are connected with the included special conical connectors (60mm). This truss and all other Global Truss series can be powder coated in every RAL colour.

TECHNISCHE DATEN

Rohrdurchmesser Hauptrohr: 50 mm
 Wandstärke: 4,0 mm
 Material: Al EN AW-6082 T6
 Rohrdurchmesser Brace: 25 mm
 Konische Verbinder: enthalten

TECHNICAL DATA

Pipe diameter: 50 mm
 Wall thickness: 4,0 mm
 Material: Al EN AW-6082 T6
 Brace diameter: 25 mm
 Connectors: included



LOAD TABLE

Das Eigengewicht der Traverse ist in der Belastungstabelle berücksichtigt.
 The dead load of the truss is considered in the load table.

Span	Uniform distribution load	Deflection	Center point load		point load in third-point		point load in quarter-point		point load in 1/5 Punkten	
			Deflection	kg	Deflection	kg	Deflection	kg	Deflection	kg
m	kg / m	cm	cm	kg	cm	kg	cm	kg	cm	kg
4,00	861,00	0,32	1403,00	0,21	1050,00	0,27	829,00	0,30	682,00	0,31
5,00	695,00	0,64	1306,00	0,39	978,00	0,49	778,00	0,55	645,00	0,58
6,00	603,00	1,16	1217,00	0,64	912,00	0,80	730,00	0,89	611,00	0,95
7,00	501,00	1,79	1137,00	0,95	851,00	1,20	686,00	1,34	578,00	1,44
8,00	413,00	2,53	1063,00	1,35	796,00	1,69	646,00	1,90	548,00	2,05
9,00	342,00	3,38	997,00	1,82	746,00	2,28	609,00	2,58	520,00	2,79
10,00	285,00	4,33	936,00	2,38	700,00	2,97	575,00	3,37	484,00	3,60
11,00	235,00	5,28	880,00	3,02	659,00	3,77	544,00	4,29	449,00	4,49
12,00	195,00	6,29	828,00	3,76	620,00	4,67	515,00	5,33	418,00	5,49
13,00	164,00	7,39	781,00	4,58	585,00	5,67	480,00	6,40	389,00	6,59
14,00	140,00	8,58	737,00	5,50	552,00	6,79	448,00	7,58	364,00	7,81
15,00	120,00	9,87	696,00	6,52	522,00	8,03	419,00	8,86	341,00	9,13
16,00	104,00	11,24	658,00	7,64	494,00	9,37	393,00	10,24	320,00	10,57
17,00	90,00	12,71	622,00	8,87	467,00	10,84	368,00	11,74	300,00	12,11
18,00	79,00	14,28	589,00	10,21	442,00	12,43	346,00	13,35	282,00	13,78
19,00	7,000	15,93	558,00	11,66	419,00	14,14	325,00	15,07	266,00	15,55
20,00	62,00	17,69	528,00	13,22	397,00	15,98	306,00	16,90	250,00	17,45
21,00	55,00	19,54	500,00	14,91	377,00	17,94	287,00	18,78	236,00	19,46
22,00	49,00	21,49	473,00	16,71	357,00	20,04	267,00	20,67	222,00	21,60
23,00	43,00	23,54	448,00	18,65	339,00	22,27	249,00	22,67	207,00	23,69
24,00	39,00	25,69	424,00	20,72	321,00	24,64	232,00	24,77	193,00	25,84

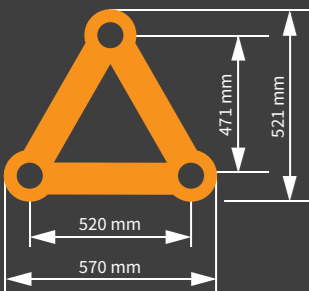

GERADEN | STRAIGHTS

CODE	Länge length	Gewicht weight
F52060	60 cm	14,7 kg
F52080	80 cm	16,0 kg
F52160	160 cm	25,0 kg
F52240	240 cm	34,6 kg
F52320	320 cm	44,0 kg



90° ECKE | CORNER C21

CODE F52C21



19,0 kg

90° ECKE | CORNER C24

CODE F52C24



11,2 kg

X-STÜCK | JOINT C41

CODE F52C41



15,7 kg

T-STÜCK | JOINT T35

CODE F52T35



12,3 kg

F52 BASE

CODE F52BA

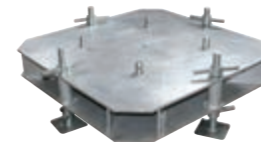

F44 TOP

CODE F44TOP



F52 SLEEVE

CODE F52SLEEVE



F52 AUSLEGEARM

CODE GS-F52-49214



Zubehör/Accessories

KONUS CONE

CODE 50171



VERBINDER SET CONNECTOR SET

Konus, Bolzen & R-Clip
 cone, pin and r-clip.
 CODE F52V



F52 VERBINDER F52 CONNECTOR

CODE F52-HALF-CON



STAHLSTIFT STEEL PIN

mit Sicherungssplint
 with safety
 CODE 5018



F102



Das F102 Traversensystem von Global Truss ist ein 4-Punkt Schwerlast-System mit einem Außenmaß von 62cm x 100cm. Das faltbare Traversensystem wurde speziell für den mobilen Einsatz mit großen Spannweiten und extrem hohen Traglasten konzipiert. Durch das Zusammenklappen der Traverse verringert sich das Transportvolumen um mehr als 50%. Ausgelegt ist dieses Traversensystem für eine Spannweite bis zu 40m.

Die F102 Traverse ist aus 50x4mm Gurtrohren und 48x3mm Diagonalbracings aus Aluminium gefertigt. Verbunden werden die Traversen mit speziellen konischen Verbindern (60mm), welche im Lieferumfang enthalten sind. Wie alle Global Truss Traversen lässt sich auch diese in beliebigen Farben pulverbeschichten.

The F102 truss series by Global Truss is a TÜV approved 4-point heavy duty system with an external dimension of 62 x 100cm. This foldable truss system was built for mobile use with large spans and extreme loads. When folded the transportation volume is reduced by 50%. A maximum span of up to 40 meters can be created with this system.

The F52 truss is built with 50 x 4mm main tubes and 48 x 3mm diagonal braces of aluminium. The truss pieces are connected with the included special conical connectors (60mm). This truss and all other Global Truss series can be powder coated in every RAL colour.

TECHNISCHE DATEN

Rohrdurchmesser Hauptrohr: 50 mm
 Wandstärke: 4,0 mm
 Material: Al EN AW-6082 T6
 Rohrdurchmesser Brace: 48 mm
 Konische Verbinder: enthalten

TECHNICAL DATA

Pipe diameter: 50 mm
 Wall thickness: 4,0 mm
 Material: Al EN AW-6082 T6
 Brace diameter: 48 mm
 Connectors: included



GERADEN | STRAIGHTS

CODE	Länge length	Gewicht weight
F102050	50 cm	15,5 kg
F102100	100 cm	29,2 kg
F102200	200 cm	43,5 kg
F102300	300 cm	56,2 kg

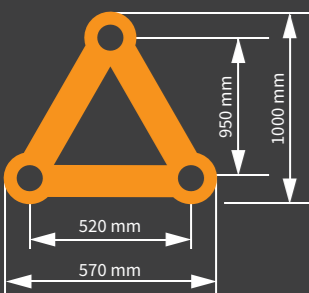

LOAD TABLE

Span	Uniform distribution load		Center point load		Point load in third-point		Point load in quarter-point		Point load in fifth-point	
	kg / m	Deflection cm	kg	Deflection cm	kg	Deflection cm	kg	Deflection cm	kg	Deflection cm
10,00	297,00	1,14	1785,00	1,10	1048,00	1,10	765,00	1,12	608,00	1,13
15,00	200,00	4,02	1367,00	3,04	838,00	3,16	633,00	3,31	517,00	3,42
20,00	116,00	7,93	1069,00	6,18	674,00	6,54	524,00	6,98	437,00	7,33
25,00	67,00	12,50	836,00	10,64	542,00	11,42	418,00	12,04	348,00	12,58
30,00	40,00	18,21	602,00	15,89	431,00	17,93	301,00	17,63	251,00	18,30
35,00	24,00	25,11	420,00	22,54	315,00	25,39	210,00	24,47	175,00	25,21
40,00	14,00	33,28	270,00	30,82	203,00	33,56	135,00	32,67	113,00	33,38

Das Eigengewicht der Traverse ist in der Belastungstabelle berücksichtigt.
 The dead load of the truss is considered in the load table.

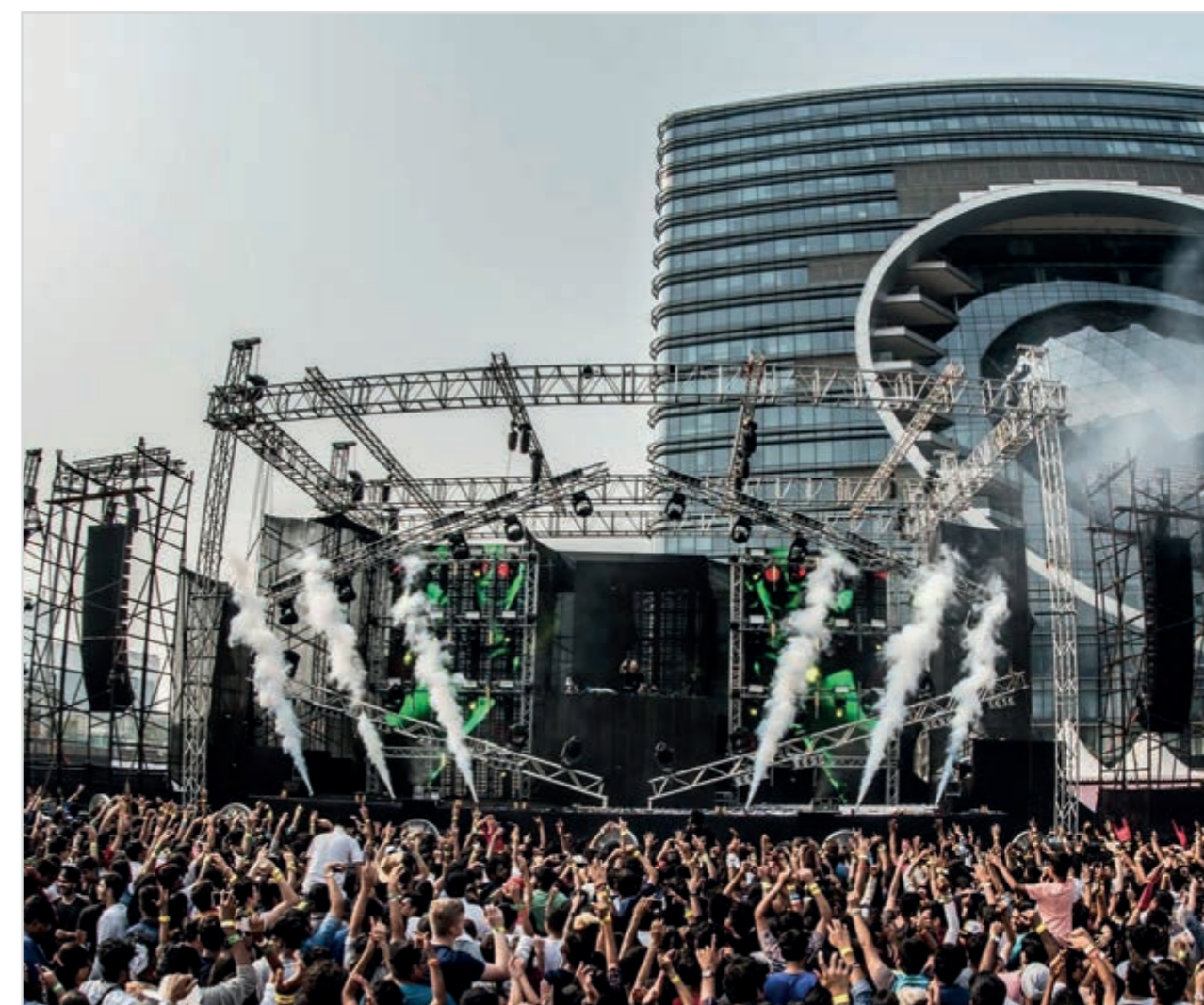

IM TYPE

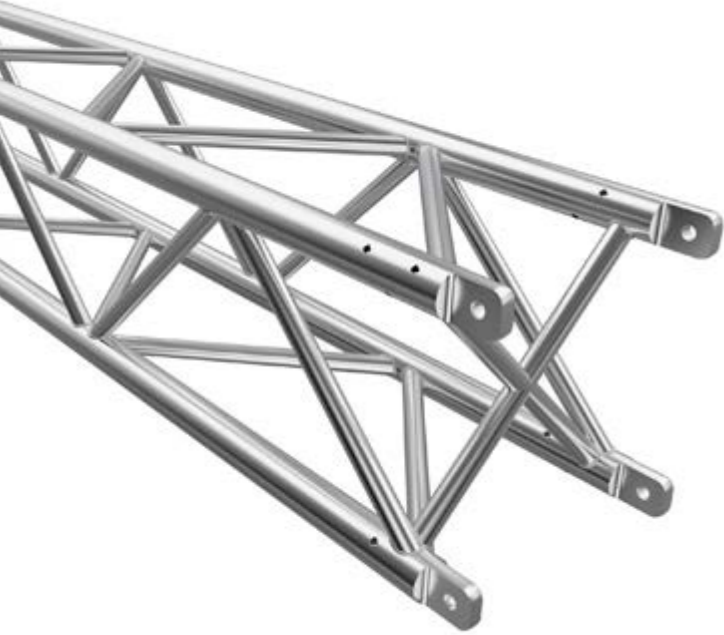

Das iM-Type Traversensystem von Global Truss ist ein 4-Punkt Schwerlast-System mit einem Außenmaß von 35cm. Dieses System zeichnet sich durch sehr hohe Belastung bei kompakter Bauform aus. Die Anwendungsbereiche sind große Ground-Support und Outdoor-Anwendungen. Durch ihre hohe Knicksicherheit eignet sich diese Traverse auch für Vertikalanwendungen. Ausgelegt ist dieses Traversensystem für eine Spannweite bis zu 30m.

Die iM-Type Traverse ist aus 48x4mm Gurtrohren und 25x3mm Diagonalbracings aus Aluminium gefertigt. Verbunden werden die Traversen mit Gabelkopfverbindern. Wie alle Global Truss Traversen lässt sich auch diese in beliebigen Farben pulverbeschichten

The iM-type truss series by Global Truss is a TÜV approved 4-point heavy duty system with an external dimension of 35cm. This system stands out with its very high load capacity and the compact build. It can be used as a ground support or for outdoor applications. Due to its rigidity this system can also be used for vertical applications. A maximum span of up to 30 meters can be created with this system.

The iM-type truss is built with 48 x 4mm main tubes and 25 x 3mm diagonal braces of aluminium. The truss pieces are connected with fork connectors. This truss and all other Global Truss series can be powder coated in every RAL colour.

An allen M-Type-Eckelementen von Global Truss engineered by Camco sind die Gabelverbinder für die zwei horizontalen Abgänge in Richtung der Haupttragrohre eingesplintet - die Verbinder für die anderen horizontalen und vertikalen Abgänge sind angeschweißt.

Betrachten Sie nun das Eckelement in der Art, dass - in waagrechtem Einbau - die männlichen (male) eingesplinteten Teile der Gabelverbinder auf die 12-Uhr-Position einer gedachten Uhr zeigen.

Für männliche Verbinder an der 12-Uhr-Position setzen Sie in der Typenbezeichnung des Eckelements an die erste Stelle hinter dem Bindestrich ein M (male). Beispiel: MC-M.... Sind an der 12-Uhr-Position keine Verbinder vorhanden, setzen Sie stattdessen eine 0. Beispiel: MC-0.... Fügen Sie nun entsprechend an

die zweite, dritte und vierte Stelle hinter dem Strich nacheinander die Zeichen M (male), F (female) bzw. 0 (nicht vorhanden) für die horizontalen Abgänge an der 3-Uhr, 6-Uhr und 9-Uhr-Position ein. Beispiel: MC-MMF.

Wenn das Eckelement zusätzlich vertikale Abgänge besitzt, geben Sie diese in der gleichen Weise nach einem weiteren Strich in der Typenbezeichnung an: an der ersten Stelle für den Abgang nach unten, an der zweiten Stelle für den Abgang nach oben. Auch hier gilt: Ist kein Verbinder vorhanden, setzen Sie stattdessen eine 0. Beispiel: MC-MFFM-0F.

Sollten auf eine 0 in der gleichen Ebene nur weitere Nullen folgen, werden diese weggelassen.

Beispiele:
MC-MF00 = MC-MF, MC-M000-F = MC-M-F

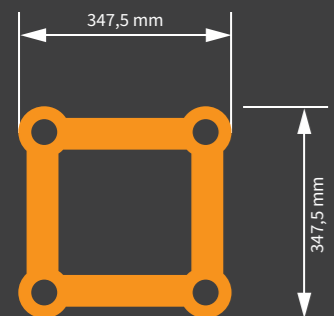

LOAD TABLE

Stützweite (Einfeldträger) m	4,00	6,00	8,00	10,00	12,00	14,00	16,00	18,00	20,00	22,00	24,00	26,00	28,00	30,00
Gleichlast vertikal kN/m	10,70	5,90	3,28	2,06	1,40	1,00	0,74	0,57	0,44	0,35	0,28	0,22	0,18	0,14
Gleichlast horizontal kN/m	9,15	5,90	3,28	2,06	1,40	1,00	0,74	0,57	0,44	0,35	0,28	0,22	0,18	0,14
Gleichlast einseitig kN/m	6,38	4,22	3,14	2,06	1,40	1,00	0,74	0,57	0,44	0,35	0,28	0,22	0,18	0,14
mittige Einzellast kN/26,80	17,70	13,10	10,30	8,40	7,01	5,95	5,10	4,40	3,81	3,30	2,85	2,46		2,10
Einzellast in Drittelpunkten kN	18,96	13,28	9,83	7,73	6,30	5,26	4,46	3,83	3,30	2,86	2,48	2,14	1,84	1,58
Einzellast in Viertelpunkten kN	13,40	8,85	6,55	5,15	4,20	3,51	2,98	2,55	2,20	1,90	1,65	1,43	1,23	1,05

Das Eigengewicht der Traverse ist in der Belastungstabelle berücksichtigt.
The dead load of the truss is considered in the load table.

GERADEN | STRAIGHTS

CODE	Länge length	Gewicht weight
IM-0270	27,00 cm	6,0 kg
IM-0390	39,00 cm	9,6 kg
IM-04475	44,75 cm	10,3 kg
IM-0500	50,00 cm	10,5 kg
IM-0666	66,60 cm	11,7 kg
IM-1243	124,30 cm	17,6 kg
IM-1820	182,00 cm	23,6 kg
IM-2400	240,00 cm	29,8 kg
IM-3000	300,00 cm	36,0 kg
IM-3556	355,60 cm	45,0 kg
IM-4140	414,00 cm	54,0 kg

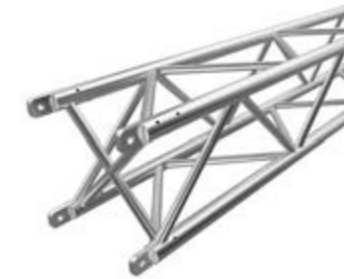

KREISSTÜCKE | CIRCLE PARTS

CODE	Ø Kreis circle	Kreisstück circle part
IM-R20-90	4,0 m	1 Stück 90°
IM-R40-30	8,0 m	1 Stück 30°
IM-R50-30	10,0 m	1 Stück 30°



SLEEVE

CODE MSC-MMFF

- für iM-Type Tower
- for iM-Type tower



26,2 kg 440 610 610

6-WEGE ECKE | 6-WAY CORNER

CODE MC-MFFM-FM



13,4 kg 500 500

4-WEGE ECKE | 4-WAY CORNER

CODE MC-MFF-F



11,5 kg 425 500 500

2-WEGE ECKE | 2-WAY CORNER

CODE MC-0MF



11,5 kg 348 500 500

3-WEGE ECKE | 3-WAY CORNER

CODE MC-0MF-F

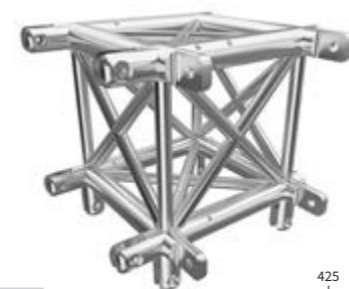

11,5 kg 425 500 500

6-WEGE ECKE | 6-WAY CORNER

CODE MC-MMFF-FM



13,4 kg 500 500 500

STAHL BODENPLATTE

BASE PLATE STEEL

CODE M-BPS-M Male
CODE M-BPS-F Female



1,5 kg 50 350 350

IL TYPE

Das iL-Type Traversensystem von Global Truss ist ein 4-Punkt Schwerlast-System mit einem Außenmaß von 62cm. Dieses System zeichnet sich durch sehr hohe Belastung bei kompakter Bauform aus. Die Anwendungsbereiche sind große Ground-Support und Outdoor-Anwendungen mit hoher Belastung. Ausgelegt ist dieses Traversensystem für eine Spannweite bis zu 30m.

Die iL-Type Traverse ist aus 48x4mm Gurtrohren und 25x3mm bzw. 32x3mm Bracings aus Aluminium gefertigt. Verbunden werden die Traversen mit Gabelkopfverbindern. Wie alle Global Truss Traversen lässt sich auch diese in beliebigen Farben pulverbeschichten

The iL-type truss series by Global Truss is a TÜV approved 4-point heavy duty system with an external dimension of 62cm. This system stands out with its very high load capacity and the compact build. It can be used as a ground support or for outdoor applications with high loads. A maximum span of up to 30 meters can be created with this system.

The iL-type truss is built with 48 x 4mm main tubes and 25 x 3mm diagonal braces of aluminium. The truss pieces are connected with fork connectors. This truss and all other Global Truss series can be powder coated in every RAL colour.

An allen L-Type-Eckelementen von Global Truss engineered by Camco sind die Gabelverbinder für die zwei horizontalen Abgänge in Richtung der Haupttragrohre eingesplintet - die Verbinder für die anderen horizontalen und vertikalen Abgänge sind angeschweißt.

Betrachten Sie nun das Eckelement in der Art, dass - in waagrecht Einbau - die männlichen (male) eingesplinteten Teile der Gabelverbinder auf die 12-Uhr-Position einer gedachten Uhr zeigen.

Für männliche Verbinder an der 12-Uhr-Position setzen Sie in der Typenbezeichnung des Eckelements an die erste Stelle hinter dem Bindestrich ein M (male). Beispiel: LC-M.... Sind an der 12-Uhr-Position keine Verbinder vorhanden, setzen Sie stattdessen eine 0. Beispiel: LC-0.... Fügen Sie nun entsprechend an die zweite, dritte und vierte Stelle hinter dem Strich nacheinander die Zeichen M (male), F (female) bzw. 0 (nicht vorhanden) für die horizontalen Abgänge an der 3-Uhr, 6-Uhr und 9-Uhr-Position ein. Beispiel: LC-MM0F.

Wenn das Eckelement zusätzlich vertikale Abgänge besitzt, geben Sie diese in der gleichen Weise nach einem weiteren Strich in der Typenbezeichnung an: an der ersten Stelle für den Abgang nach unten, an der zweiten Stelle für den Abgang nach oben. Auch hier gilt: Ist kein Verbinder vorhanden, setzen Sie stattdessen eine 0. Beispiel: LC-MFFM-0F.

Sollten auf eine 0 in der gleichen Ebene nur weitere Nullen folgen, werden diese weggelassen. Beispiele: LC-MF00 = LC-MF, LC-M000-F = LC-M-F

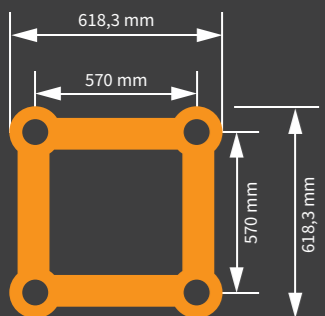
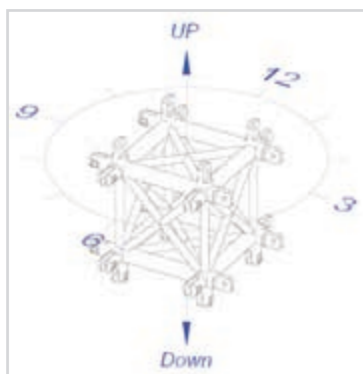
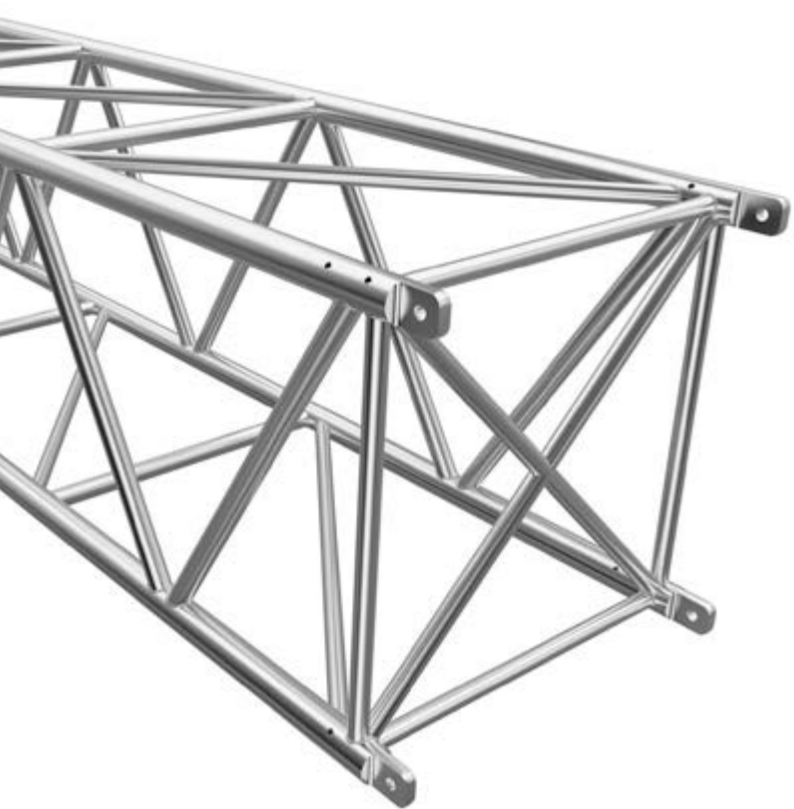

LOAD TABLE

Das Eigengewicht der Traverse ist in der Belastungstabelle berücksichtigt.
The dead load of the truss is considered in the load table.

Stützweite (Einfeldträger) m	4,00	6,00	8,00	10,00	12,00	14,00	16,00	18,00	20,00	22,00	24,00	26,00	28,00	30,00
Gleichlast vertikal kN/m	12,95	5,68	4,44	3,21	2,77	2,00	1,50	1,15	0,91	0,73	0,59	0,48	0,39	0,33
Gleichlast vertikal punktuell kN/m	16,24	10,78	6,40	4,05	2,77	2,00	1,50	1,15	0,91	0,73	0,59	0,48	0,39	0,33
Gleichlast horizontal kN/m	5,47	3,64	2,73	2,19	1,82	1,56	1,37	1,15	0,91	0,73	0,59	0,48	0,39	0,33
Gleichlast einseitig kN/m	7,71	5,68	4,11	3,42	2,33	1,78	1,33	1,02	0,80	0,64	0,51	0,42	0,34	0,28
mittige Einzellast kN42,16	30,74	24,19	19,94	16,61	13,98	11,97	10,37	9,07	7,98	7,04	6,23	5,52	4,88	
Einzellast in Drittelpunkten kN	28,00	21,08	16,90	14,10	11,80	9,91	8,48	7,33	6,40	5,62	4,94	4,36	3,84	3,38
Einzellast in Viertelpunkten kN	21,64	16,97	12,81	10,12	8,30	6,99	5,98	5,19	4,53	3,99	3,52	3,12	2,76	2,44

GERADEN | STRAIGHTS

CODE	Länge length	Gewicht weight
IL-0600	60 cm	15,6 kg
IL-1200	120 cm	24,0 kg
IL-2400	240 cm	37,8 kg
IL-3000	300 cm	45,9 kg

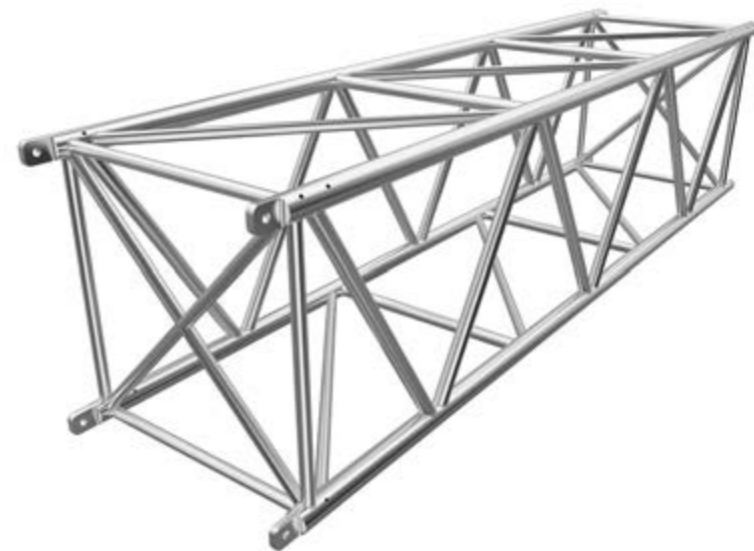

2-WEGE ECKE | 2-WAY CORNER CODE LC-00F-F



21,8 kg 617 667

6-WEGE ECKE | 6-WAY CORNER CODE LC-MFFM-FM

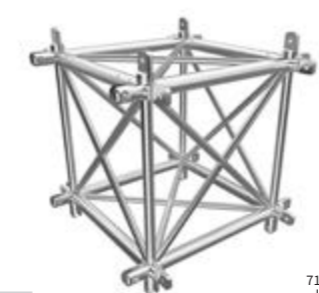

22,8 kg 717 717

4-WEGE ECKE | 4-WAY CORNER CODE LC-MMF-F

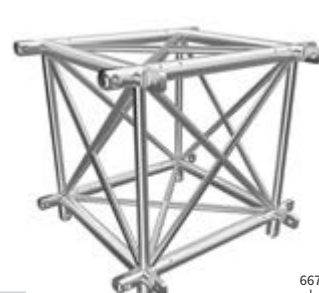

22,8 kg 717 667

2-WEGE ECKE | 2-WAY CORNER CODE LC-MF



21,8 kg 617 667

6-WEGE ECKE | 6-WAY CORNER CODE LC-MMFF-FM

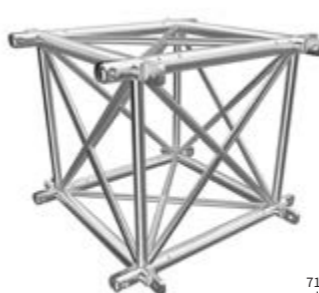

22,8 kg 717 717

4-WEGE SLEEVE | 4-WAY SLEEVE CODE LSC-MFFM

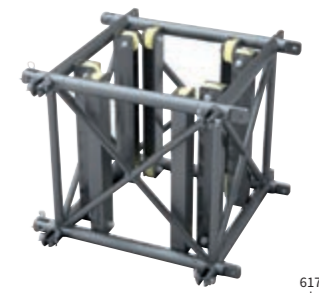

28,0 kg 717 717



SILENCER CODE SIL10



Keep it simple! Mit dem von Global Truss entwickelten Silencer, einem Dämpfer aus Gummi, der einfach auf den Traversenbolzen gesteckt wird, verringert sich die Lautstärke beim Hämmern der Traversen um die Hälfte und hohe Frequenzen, wenn Metall auf Metall trifft, werden deutlich gedämpft. Bei der Herstellung wird eine spezielle Gummimischung verwendet, die den Silencer flexibel, aber dennoch hart genug macht, um die Krafteinwirkung eines Hammers effektiv zu übertragen und das Material des Bolzens und des Hammers zu schonen. Beim Ablegen einer Traverse auf den Boden liegt diese nun geschützt auf den Silencern auf und Beschädigungen des Untergrunds und der Traverse selbst werden dadurch vermieden. Bei schwarzen Traversen verdeckt der Silencer zudem die silbernen Bolzen.

Keep it simple! Global Truss has developed the Silencer, a rubber damper that is simply pushed on to the end of a truss pin to reduce noise when assembling truss structures. The silencer will decrease the volume when hammering truss pins by around 50% whilst dampening the high pitch frequencies significantly. A special rubber blend is being used in production which makes the Silencer flexible yet hard enough to transfer the force of the hammer effectively, and whilst preserving the material of the pin and the copper hammer. The Silencer has been designed to be left on the truss pins, whilst fitted to the truss, providing protection not only to the truss but also the ground it is sitting upon. Another added feature is that it offers added camouflage when silvers pins are used on black truss.

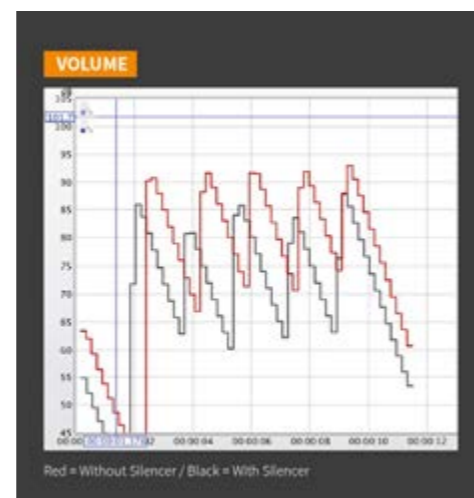
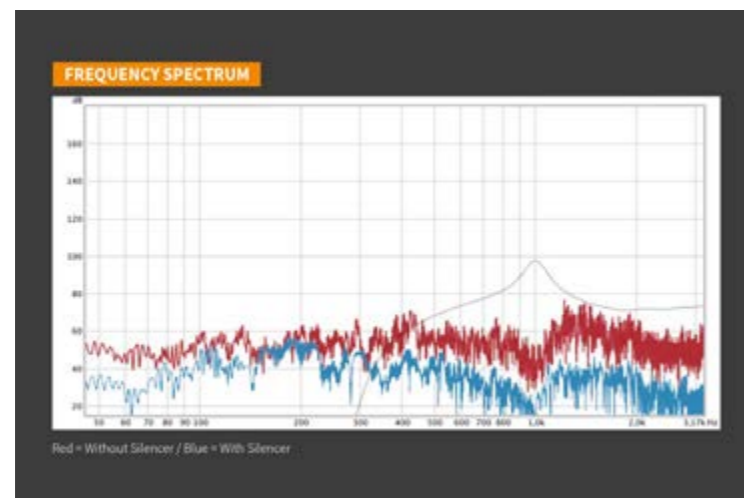

CASE OHNE INLAY | CASE WITHOUT INLAY

CODE 117277

Maße | Dimensions: 415 x 270 x 150 mm



CASE MIT INLAY | CASE WITH INLAY für 135 Bolzen | for 135 bolts

CODE 117278

Maße | Dimensions: 415 x 270 x 150 mm

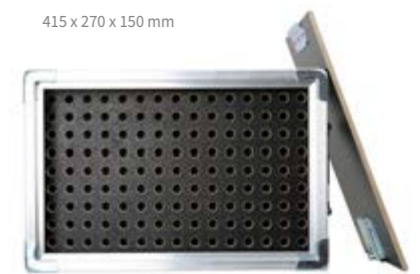

CASE MIT INLAY | CASE WITH INLAY für 108 Bolzen & Splintfach | for 108 bolts and splint shelf

CODE 117281

Maße | Dimensions: 415 x 270 x 150 mm



CASE MIT INLAY | CASE WITH INLAY für 40 konische Verbinder | for 40 conical connectors

CODE 117279

Maße | Dimensions: 415 x 270 x 150 mm



CASE MIT INLAY | CASE WITH INLAY für 24 konische Verbinder & 60 Bolzen | for 24 conical connectors & 60 bolts

CODE 117280

Maße | Dimensions: 415 x 270 x 150 mm



CASE MIT INLAY | CASE WITH INLAY für 24 konische Verbinder, 48 Bolzen & Splintfach | for 24 conical connectors, 48 bolts & splint shelf

CODE 117246

Maße | Dimensions: 415 x 270 x 150 mm



STACKING CASE für 48 konische Trussverbinder

stacking case for 48 pieces
of conical connector

CODE 27263



TRAVERSEN STAPELADAPTER | STACKABLE TRUSS ADAPTER

Material: Holz Birke Multiplex
 Passend für: 2x F34/F33/F32
 Breite: 60cm
 Material: Wood Birch Multiplex
 Fits with: 2x F34/F33/F32
 Width: 60cm

CODE 1285



TRAVERSEN STAPELADAPTER

Material: Holz Birke Multiplex
 Passend für: 4x F34 oder 3x F44
 Breite: 120cm
 Material: Wood Birch Multiplex
 Fits with: 4x F34 oder 3x F44
 Width: 120cm
 CODE 1290



ROLLWAGEN | TROLLEY FÜR 2 X F34

CODE 1281 Bohrung für 2 Rollen / with hole for 2 wheels
 CODE 1282 Bohrung für 3 Rollen / with hole for 3 wheels
 CODE 1283 Bohrung für 4 Rollen / with hole for 4 wheels



ROLLWAGEN | TROLLEY FÜR 4X F34 / 3X F44

CODE 1291 Bohrung für 2 Rollen / with hole for 2 wheels
 CODE 1292 Bohrung für 4 Rollen / with hole for 4 wheels



TENTE BLUE WHEELS

CODE 27174 ungebremst / unbraked
 CODE 27175 gebremst / braked
 CODE 100073 Schraubensatz für eine Rolle / Screw set for one wheel



**KUPFERHAMMER „COPPERCONE“ 500G MIT HICKORYSTIEL
 COPPER HAMMER „COPPERCONE“ 500G WITH HICKORY HANDLE**
 CODE 112274

Der GLOBAL TRUSS Kupferhammer schont die Trusspins beim Ein- und Ausschlagen, da Kupfer ein weiches Material gegenüber dem Stahlpin ist. Dies macht die Trusspins langlebiger.

The GLOBAL TRUSS Kupferhammer already truss pins boarding and knocking, since copper is a softer material than the steel pin. This makes the durable truss pins.



HAMMER FÜR F14 TRAVERSEN

CODE F14HAMMER
 Material: steel
 Handle: rubberized
 Weight: approx. 1 kg



RIGGER HAND

CODE 40021



Die Global Truss Rigger Hand ist eine praktische Trusszange zum einfachen Verbinden von zwei Traversenstücken. Gerade bei großen Traversenbauten erspart der Einsatz der Rigger Hand einiges an Kraftaufwand.

- verstellbarer Schub
- ausziehbarer Griff



The Global Truss Rigger Hand is a practical truss tongs which enables an easy connection of two truss pieces. For large truss constructions the use of the rigger hand saves a lot of effort.

- Adjustable shear
- telescopic handle



**ANSCHLAGPUNKT F33/F34
 PICK POINT F33/F34**

CODE GIZMO29 SILBER/SILVER
 CODE GIZMO29-B STAGE BLACK

Kompatibel | compatibility F33 / F33PL / F34 / F34P
 Maße | Dimensions 340 x 220 x 60 mm
 Load | load 1500kg WLL
 750kg over audience

**ANSCHLAGPUNKT F43/F44
 PICK POINT F43/F44**

CODE GIZMO40 SILBER/SILVER
 CODE GIZMO40-B STAGE BLACK

Kompatibel | compatibility F43 / F44 / F44P
 Maße | Dimensions 450 x 250 x 80 mm
 Load | load 1500kg WLL
 750kg over audience

**ANSCHLAGPUNKT IM-TYPE
 PICK POINT IM-TYPE**

CODE GIZMO35 SILBER/SILVER
 CODE GIZMO35-B STAGE BLACK

Kompatibel | compatibility iM-Type
 Maße | Dimensions 450 x 250 x 80 mm
 Load | load 1500kg WLL
 750kg over audience

CORNERBRAKE MIT KLEMME | CORNER BRAKE WITH CLAW

CODE 5050 Länge/length 1m
CODE 5051 Länge/length 2m
CODE 5052 Länge/length 3m



F22
F23
F24
F31
F32
F33
F33PL
F34
F34P
F34PL
F42
F43
F44
F44P
F52
F54

TRAVERSENADAPTER MIT RINGÖSE (VARIABLE) | TRUSS ADAPTER WITH EYELET (VARIABLE)

CODE 5039-1
Kompatibel | compatibility F32-F44 (48-51 mm)
Breite Adapter | wide adapter 290-390 mm (variabel)
Zugbelastung | tensile load 100 kg
Abgang | retaining screw Ringöse
Verschluß | screw plug M10 Flügelmutter



F22
F23
F24
F31
F32
F33
F33PL
F34
F34P
F34PL
F42
F43
F44
F44P
F52
F54

CORNERBRAKE VERSTELLBAR | CORNERBRAKE ADJUSTABLE

verstellbar von 800 - 1200mm
adjustable from 800 up to 1200mm
CODE CORNERB



F22
F23
F24
F31
F32
F33
F33PL
F34
F34P
F34PL
F42
F43
F44
F44P
F52
F54

TRAVERSENADAPTER MIT RINGÖSE | TRUSS ADAPTER WITH EYELET

CODE 5039-2
Kompatibel | compatibility F22-F24 (32-35 mm)
Breite Adapter | wide adapter 220 mm
Zugbelastung | tensile load 100 kg
Abgang | retaining screw Ringöse
Verschluß | screw plug M10 Flügelmutter

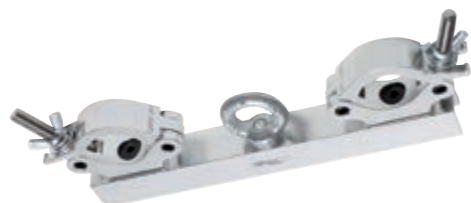

F22
F23
F24
F31
F32
F33
F33PL
F34
F34P
F34PL
F42
F43
F44
F44P
F52
F54

TRUSSAUFNEMER FÜR KURBELSTATIV | TRUSS ADAPTER FOR WIND STAND

CODE 814
Kompatibel | compatibility F32-F44 (48-51 mm)
Breite Adapter | wide adapter 290-390 mm (variabel)
Belastung | load 100 kg
Abgang | retaining screw TV-Zapfen
Verschluß | screw plug M10 Flügelmutter



F22
F23
F24
F31
F32
F33
F33PL
F34
F34P
F34PL
F42
F43
F44
F44P
F52
F54

WANDHALTER|WALLBRACKET F43/F44

CODE 118741 Silber / silver
CODE 118744 Stage Black



F22
F23
F24
F31
F32
F33
F33PL
F34
F34P
F34PL
F42
F43
F44
F44P
F52
F54

WANDHALTER|WALLBRACKET F33/F34

CODE 115641 Silber / silver
CODE 115642 Schwarz / black



F22
F23
F24
F31
F32
F33
F33PL
F34
F34P
F34PL
F42
F43
F44
F44P
F52
F54



SPACER MALE UND SPACER FEMALE - STANDARDGRÖSSEN/STANDARD SIZES

CODE 5019M	F 32-44 Abstandshalter	male 105 mm	CODE 5019M-PL	F 32-44 PL Abstandshalter	male 105 mm
CODE 5020M	F 32-44 Abstandshalter	male 170 mm	CODE 5020M-PL	F 32-44 PL Abstandshalter	male 170 mm
CODE 5021M	F 32-44 Abstandshalter	male 210 mm	CODE 5021M-PL	F 32-44 PL Abstandshalter	male 210 mm
CODE 5019	F 32-44 Abstandshalter	female 105 mm	CODE 5019-PL	F 32-44 PL Abstandshalter	female 105 mm
CODE 5020	F 32-44 Abstandshalter	female 170 mm	CODE 5020-PL	F 32-44 PL Abstandshalter	female 170 mm
CODE 5021	F 32-44 Abstandshalter	female 210 mm	CODE 5021-PL	F 32-44 PL Abstandshalter	female 210 mm

SPACER MALE - SONDERGRÖSSEN/CUSTOM SIZES

CODE S10	Spacer	1 cm male	CODE S90	Spacer	9 cm male	CODE S180	Spacer	18 cm male
CODE S10PL	Spacer	1 cm male PL	CODE S90PL	Spacer	9 cm male PL	CODE S180PL	Spacer	18 cm male PL
CODE S20	Spacer	2 cm male	CODE S100	Spacer	10 cm male	CODE S190	Spacer	19 cm male
CODE S20PL	Spacer	2 cm male PL	CODE S100PL	Spacer	10 cm male PL	CODE S190PL	Spacer	19 cm male PL
CODE S30	Spacer	3 cm male	CODE S110	Spacer	11 cm male	CODE S200	Spacer	20 cm male
CODE S30PL	Spacer	3 cm male PL	CODE S110PL	Spacer	11 cm male PL	CODE S200PL	Spacer	20 cm male PL
CODE S40	Spacer	4 cm male	CODE S120	Spacer	12 cm male	CODE S220	Spacer	22 cm male
CODE S40PL	Spacer	4 cm male PL	CODE S120PL	Spacer	12 cm male PL	CODE S220PL	Spacer	22 cm male PL
CODE S50	Spacer	5 cm male	CODE S130	Spacer	13 cm male	CODE S230	Spacer	23 cm male
CODE S50PL	Spacer	5 cm male PL	CODE S130PL	Spacer	13 cm male PL	CODE S230PL	Spacer	23 cm male PL
CODE S60	Spacer	6 cm male	CODE S140	Spacer	14 cm male	CODE S240	Spacer	24 cm male
CODE S60PL	Spacer	6 cm male PL	CODE S140PL	Spacer	14 cm male PL	CODE S240PL	Spacer	24 cm male PL
CODE S70	Spacer	7 cm male	CODE S150	Spacer	15 cm male			
CODE S70PL	Spacer	7 cm male PL	CODE S150PL	Spacer	15 cm male PL			
CODE S80	Spacer	8 cm male	CODE S160	Spacer	16 cm male			
CODE S80PL	Spacer	8 cm male PL	CODE S160PL	Spacer	16 cm male PL			

SPACER MALE-FEMALE - SONDERGRÖSSEN/CUSTOM SIZES

CODE S60MF	Spacer	6 cm male/female	CODE S120MF	Spacer	12 cm male/female	CODE S190MF	Spacer	19 cm male/female
CODE S70MF	Spacer	7 cm male/female	CODE S130MF	Spacer	13 cm male/female	CODE S200MF	Spacer	20 cm male/female
CODE S80MF	Spacer	8 cm male/female	CODE S140MF	Spacer	14 cm male/female	CODE S210MF	Spacer	21 cm male/female
CODE S90MF	Spacer	9 cm male/female	CODE S150MF	Spacer	15 cm male/female			
CODE S100MF	Spacer	10 cm male/female	CODE S160MF	Spacer	16 cm male/female			
CODE S105MF	Spacer	10,5 cm male/female	CODE S170MF	Spacer	17 cm male/female			
CODE S110MF	Spacer	11 cm male/female	CODE S180MF	Spacer	18 cm male/female			

SPACER FÜR BOXCORNER | SPACE FOR BOX CORNER

Lieferung erfolgt ohne Boxcorner

Delivery without boxcorner

F34BOXS105F	Spacer	105 mm
F34BOXS210F	Spacer	210 mm
F44BOXS100F	Spacer	100 mm



SPACER VARIABLE | SPACER VARIABLE

SV105-170 Spacer variabel 105-170 mm

SV210-265 Spacer variabel 210-265 mm



F22
F23
F24
F31
F32
F33
F33PL
F34
F34P
F34PL
F42
F43
F44
F44P
F52
F54

HALBKONUS | HALF CONE
Halber Konusverbinder M-10
Gewinde für F32-F44 (PL),
inkl. Steel Pin.

CODE 5003 F32-F44
CODE 5003PL F33PL-F34PL
CODE 5003S Sleeveblock
CODE 5003SQX F34QX (ohne Bolzen, R-Clip)

F22
F23
F24
F31
F32
F33
F33PL
F34
F34P
F34PL
F42
F43
F44
F44P
F52
F54



HALBKONUS | HALF CONE
CODE F34BOXC Standard M10
CODE F34BOXD Standard M12
CODE F34BOXCPL PL-Version M10
CODE F34BOXDPL PL-Version M12
CODE F34BOXDQX F34QX (ohne Bolzen, R-Clip)

F22
F23
F24
F31
F32
F33
F33PL
F34
F34P
F34PL
F42
F43
F44
F44P
F52
F54



KONUSVERBINDER | CONE
für F32-F44, F31PL-F34PL

CODE 5009 F32-F44
CODE 5009PL F33PL-F34PL
CODE 5009QX F34QX

F22
F23
F24
F31
F32
F33
F33PL
F34
F34P
F34PL
F42
F43
F44
F44P
F52
F54



HALBKONUS | HALF CONE
Halber Konusverbinder
M-8 Gewinde für F22-F24,
inkl. Steel Pin.

CODE 5015

F22
F23
F24
F31
F32
F33
F33PL
F34
F34P
F34PL
F42
F43
F44
F44P
F52
F54



KONUSVERBINDER | CONE
für F22-F24, inkl. Steel Pin.

CODE 5014

F22
F23
F24
F31
F32
F33
F33PL
F34
F34P
F34PL
F42
F43
F44
F44P
F52
F54



HALB KONUS FÜR BOXCORNER
HALF CONE FOR BOXCORNER
CODE F24BOX-C

F22
F23
F24
F31
F32
F33
F33PL
F34
F34P
F34PL
F42
F43
F44
F44P
F52
F54



KONUSVERBINDER | CONE
Konusverbinder für F32-F44,
Lieferung inkl. Steel Pin.

CODE 5002 F32-F44
CODE 5002PL F33PL-F34PL
CODE 5002QX F34QX

F22
F23
F24
F31
F32
F33
F33PL
F34
F34P
F34PL
F42
F43
F44
F44P
F52
F54



KONUSVERBINDER | CONE
F32 AUF F34
Lieferung erfolgt ohne Bolzen
und Splint

CODE F3432L Konusverbinder links
CODE F3432R Konusverbinder rechts

F22
F23
F24
F31
F32
F33
F33PL
F34
F34P
F34PL
F42
F43
F44
F44P
F52
F54



KONUSVERBINDER | CONE
PL AUF GT
Adapterkonus für PL-GT Traversen.
Spezialadapter zum Verbinden
unterschiedlicher Systeme.
Lieferung ohne Bolzen und Splint.

CODE 5009PLGT

F22
F23
F24
F31
F32
F33
F33PL
F34
F34P
F34PL
F42
F43
F44
F44P
F52
F54



ABSCHLUSS-STÜCK
END CAP
Halbkonisches Abschluss-Stück
für F22-F24

CODE ST5008-1 F22-F24

F22
F23
F24
F31
F32
F33
F33PL
F34
F34P
F34PL
F42
F43
F44
F44P
F52
F54



KONISCHER STIFT
CONICAL SPLINT
Konischer Stift inkl. R-Clip
für F22-F24.

CODE 5016

F22
F23
F24
F31
F32
F33
F33PL
F34
F34P
F34PL
F42
F43
F44
F44P
F52
F54



DON'T RIG SHIT.

TRUST
Global Truss

ABSCHLUSS-STÜCK
END CAP
Halbkonisches Abschluss-Stück
für F32-F44
Nicht für PL-Version kompatibel!

CODE ST5008 F32-F44

F22
F23
F24
F31
F32
F33
F33PL
F34
F34P
F34PL
F42
F43
F44
F44P
F52
F54



KONISCHER STIFT
CONICAL SPLINT
inkl. R-Clip

CODE 5004 für F32-F44
CODE 5004P für F32-F44 (10,9)
CODE 5004PL für F33PL-F34PL
CODE 5004QX für F34QX

F22
F23
F24
F31
F32
F33
F33PL
F34
F34P
F34PL
F42
F43
F44
F44P
F52
F54



KONISCHER STIFT
CONICAL SPLINT
Konischer Stift mit M-8 Gewinde

CODE 5005 für F32-F44
CODE 5005PL für F33PL-F34PL
CODE 5005QX für F34QX

F22
F23
F24
F31
F32
F33
F33PL
F34
F34P
F34PL
F42
F43
F44
F44P
F52
F54



BODENPLATTE MULTI |
BASE PLATE MULTI (45X45CM)
Für F31-F34 und F22-F24, Stahl.
Gewicht 7,8 kg

CODE 106122



BODENPLATTE | BASE PLATE ECKIG
(80X80CM)
Für F22-F24, F32-44, Stahl.
Gewicht 36 kg

CODE 27195



TOP F32
Sonderpart für Bühnendächer
Special part for stage roof
CODE F32ROOF



Global Truss



TRAVERSENPIN "SHORT"
TRUSSPIN „SHORT“
für Messebau, inkl. R-Clip
Material: Edelstahl

for tradefair constructions, incl. R-Clip
Material: stainless steel

CODE PINSHORT

F22
F23
F24
F31
F32
F33
F33PL
F34
F34P
F34PL
F42
F43
F44
F44P
F52
F54



„R“ CLIP
CODE 8877

F22
F23
F24
F31
F32
F33
F33PL
F34
F34P
F34PL
F42
F43
F44
F44P
F52
F54



TV ZAPFEN | SPIGOT
Durchmesser/diameter 28mm, Länge/
length 110 mm, inkl. Schraube und Unter-
lagscheibe, delivery incl. srew and washer.
CODE 472 für Stativ M-10
CODE 4721 für Stativ M-12



TV ZAPFEN | SPIGOT
TV Zapfen 28 mm auf Mini TV Zapfen
M10 Gewinde
CODE 102368



Z063 INKL. SCHRAUBE M10 X 40
105153 Alu natur / Alu nature
105154 schwarz / black



AUFNAHME STAHL, RUND
verzinkt, mit Schraube
CODE 165008 Ø 35mm innen
CODE 165009 Ø 55mm innen



AUFNAHME STAHL, RUND
Ø 36 mm innen, verzinkt
CODE 165007



BOXEN ADAPTER
mit 35 mm Aufnahme inkl. Halbkonus
für 30er Truss (F31/F31PL)
CODE 65430



FLÜGELMUTTER MIT GEWINDE
CODE 600801 M8 Gewinde
CODE 101275 M12 Gewinde



GLASSCHEIBENHALTER
Glasscheibenhalter mit M10 Gewinde
CODE 77885 6-10 mm
CODE 77884 10-16 mm

Optional:
CODE 812





MONTAGESCHIENE
MOUNTING BAR
für Trussaufnahme, TV-Zapfen oder
Ring-mutter, vestellbar von 18-40 cm, ver-
zinkt
for couplers, spigot or ringnut, adjustable 18-40 cm,
galvanized
CODE 165006



HAKEN | CLAMPS SCHWARZ
CODE 116B CL-077 (19 cm)
CODE 118B CL-0714 (35 cm)
CODE 131B CL-0726 (66 cm)

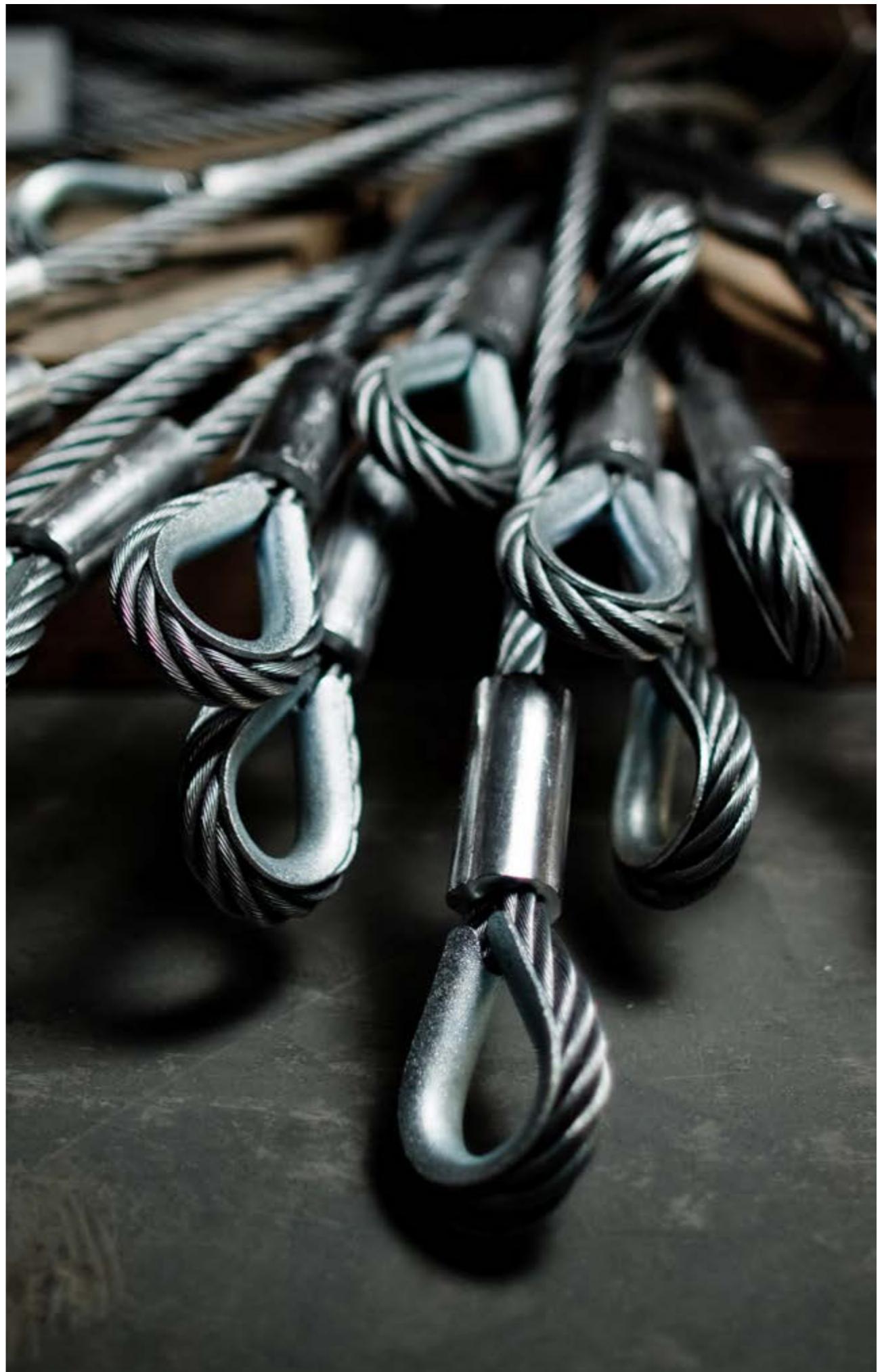

HAKEN | CLAMPS
CODE 116 CL-077 (19 cm)
CODE 118 CL-0714 (35 cm)
CODE 131 CL-0726 (66 cm)

ANSCHLAGSEILE | STEEL CABEL 14MM

6 x 37, EN 12385, 1-4, 10*
mit Fasereinlage/FC
Standard-Machart/M, sZ (früher DIN 3066/FE)
Bei einer Nennzugfestigkeit der Drähe von 1770N/qmm

CODE 10302	Nutzlänge/length 100 cm
CODE 10303	Nutzlänge/length 150 cm
CODE 10304	Nutzlänge/length 200 cm
CODE 10305	Nutzlänge/length 250 cm
CODE 10306	Nutzlänge/length 300 cm



Seil-Ø mm	Gewicht per 100 m kg	Rechnerische Bruchkraft kN	Mindest- Bruchkraft kN
14	67,8	124,0	102,0



RW	c**	l	s	Gewicht per 100 Stück ca. kg
14	32	51	3,5	11,3

* neue EN-Normen, Hinweis Seite 3, ab RW 45 nicht in Norm enthalten. ** Maß c entspricht Bolzen-Ø, Abweichungen möglich.



SICHERUNGSEILE MIT KETTENNOTGLIED | SAFETY

Sicherungsseil mit Kettennotglied verschraubbar und einseitig geöst. Die Tragkraft errechnet sich aus der Mindestbruchkraft. Diese wird durch den für den jeweiligen Einsatzzweck vorgeschriebenen Sicherheitsfaktor geteilt.

Safety cable with chain-safe-member screwable and unilateral eye. The load capacity is calculated from the minimum tensile strength. This is the objective for the purpose prescribed safety factor divided.

Safety 60 cm / 2 mm mit Kettennotglied
Sicherungsseil ohne BGVC1, Bruchkraft: 230 kg
Safety 60 cm / 2 mm, without BGVC1, tensile strength 230 kg
CODE 10114

Safety 100 cm / 4 mm mit Kettennotglied
nach DIN 56926, Bruchkraft: 885 kg
Safety 100 cm / 4 mm, DIN 56926 / BGVC1,
tensile strength 230 kg
CODE 10117

Safety 60 cm / 3 mm mit Kettennotglied
nach DIN 56926, Bruchkraft: 498 kg
Safety 60 cm / 3 mm, DIN 56926, tensile strength 230 kg
CODE 10115

Safety 60 cm / 4 mm mit Kettennotglied
nach DIN 56926
Safety 60 cm / 4 mm DIN 56926/BGVC1
CODE 10118

Safety 70 cm / 3 mm mit Kettennotglied
nach DIN 56926, Bruchkraft: 496 kg
Safety 70 cm / 3 mm, DIN 56926, tensile strength 496 kg
CODE 10116

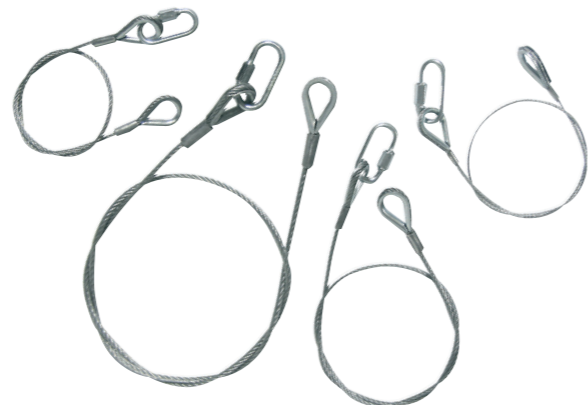

SICHERUNGSEILE NACH BGV-C1

Die Sicherungsseile des Stuttgarter Herstellers Safetex gehören zur Seilkategorie 6x19 mit Fasereinlage und sind nach BGV-C1 gefertigt. Die verzinkten Drahtseile (EN 12385-4) verfügen über zwei Kauschen nach DIN 6899 Typ BF sowie über zylindrische Pressklemmen nach DIN 3093 A. Der verzinkte Karabinerhaken verfügt zudem über eine Überwurfmutter, die gemäß BGI-810-3 nicht ausfädelbar ist. Zur exakten Bestimmung gibt ein Kennzeichnungs-Label Aufschluss über Seildurchmesser, Tragfähigkeit und Hersteller.

With 2 thimbles according to DIN 6899 type BF and cylindrical wire rope clamps according to DIN 3093 A. Wire rope zinc coated according to EN 12385-4. Construction 6 x 19 with fibre core. Zinc coated carabiner with sleeve nut, cannot thread-out according to BGI-810-3. Identification Label with rope diameter, capacity and manufacturer's instructions.

SILBER | SILVER

- Safety 60cm Ø 3mm BGV-C1, max. 5kg
CODE 113647
- Safety 60cm Ø 4mm BGV-C1, max. 10kg
CODE 113648
- Safety 60cm Ø 5mm BGV-C1, max. 15kg
CODE 119149
- Safety 60cm Ø 6mm BGV-C1, max. 22kg
CODE 119151
- Safety 80cm Ø 3mm BGV-C1, max. 5kg
CODE 113649
- Safety 100cm Ø 4mm BGV-C1, max. 16kg
CODE 113650
- Safety 100cm Ø 5mm BGV-C1, max. 25kg
CODE 119150
- Safety 100cm Ø 6mm BGV-C1, max. 36kg
CODE 119152

SCHWARZ | BLACK

- Safety 60cm Ø 3mm BGV-C1, max. 5kg
CODE 118654
- Safety 60cm Ø 4mm BGV-C1, max. 10kg
CODE 118655
- Safety 60cm Ø 5mm BGV-C1, max. 15kg
CODE 119145
- Safety 60cm Ø 6mm BGV-C1, max. 22kg
CODE 119147
- Safety 100cm Ø 4mm BGV-C1, max. 16kg
CODE 118656
- Safety 100cm Ø 5mm BGV-C1, max. 25kg
CODE 119146
- Safety 100cm Ø 6mm BGV-C1, max. 36kg
CODE 119148



DRAHTSEILHALTER TYP 50 SV II MIT RINGÖSE

CODE 104236

Drahtseilhalter M12 mit Ringöse
Für Stahlseile 4-5 mm

Anhängelasten:
bei 4 mm 150 kg (80 kg BGV C1)
bei 5 mm 250 kg (130 kg BGV C1)



**STEELFLEX
NUTZLAST 2000 KG**

- CODE 101130 Nutzlänge/length 0,5 m
- CODE 101131 Nutzlänge/length 1,0 m
- CODE 101132 Nutzlänge/length 1,5 m
- CODE 101133 Nutzlänge/length 2,0 m
- CODE 101134 Nutzlänge/length 2,5 m
- CODE 101135 Nutzlänge/length 3,0 m



**RUNDSCHLINGEN SX SCHWARZ
NUTZLAST 1200 KG**

- CODE 10210 Nutzlänge/length 0,5 m
- CODE 10211 Nutzlänge/length 1,0 m
- CODE 10212 Nutzlänge/length 1,5 m
- CODE 10213 Nutzlänge/length 2,0 m
- CODE 10218 Nutzlänge/length 2,5 m
- CODE 10224 Nutzlänge/length 3,0 m
- CODE 10226 Nutzlänge/length 4,0 m
- CODE 10221 Nutzlänge/length 5,0 m



**RUNDSCHLINGEN SX SCHWARZ
NUTZLAST 2200 KG**

- CODE 10214 Nutzlänge/length 0,5 m
- CODE 10215 Nutzlänge/length 1,0 m
- CODE 10216 Nutzlänge/length 1,5 m
- CODE 10217 Nutzlänge/length 2,0 m
- CODE 10219 Nutzlänge/length 2,5 m
- CODE 10223 Nutzlänge/length 3,0 m
- CODE 10220 Nutzlänge/length 4,0 m
- CODE 10222 Nutzlänge/length 6,0 m



TRÄGERKLEMME | BEARER CLAMP 1,0 TONNEN

Typ WHC, Flanschbreite 75-230 mm

CODE 10402

TRÄGERKLEMME | BEARER CLAMP 2,0 TONNEN

Typ WHC, Flanschbreite 75-230 mm

CODE 10403

TRÄGERKLEMME | BEARER CLAMP 3,0 TONNEN

Typ WHC, Flanschbreite 75-230 mm

CODE 10404



HOCHFESTE RINGMUTTER | SHIGH STRENGTH RING NUT

M12, Zuglast 1,5 Tonnen,
seitliche Belastung 380 kg

CODE 1070



SCHÄKEL | SHACKLE

HA2 1T 3/8-36

hochfest, geschweißt, verzinkt,
mit Schraubbefestigung

CODE 10502



SCHÄKEL | SHACKLE

HA2 2T 1/2-48

hochfest, geschweißt, verzinkt,
mit Schraubbefestigung

CODE 10507



SCHÄKEL | SHACKLE

HA2 3,25T 5/8-60

hochfest, geschweißt, verzinkt,
mit Schraubbefestigung

CODE 10503



SCHÄKEL | SHACKLE

1T 3/8" SB

hochfest, geschweißt, schwarz,
mit Schraubbefestigung

CODE 118651



SCHÄKEL | SHACKLE

2,0T 1/2" SB

hochfest, geschweißt, schwarz,
mit Schraubbefestigung

CODE 118652



SCHÄKEL | SHACKLE

3,25T 5/8" SB

hochfest, geschweißt, schwarz,
mit Schraubbefestigung

CODE 118653



SCHÄKEL | SHACKLE

HC2 1T 3/8-36

hochfest, geschweißt, verzinkt,
mit Schraubbefestigung + Mutter

CODE 10504



SCHÄKEL | SHACKLE

HC2 2T 1/2-48

hochfest, geschweißt, verzinkt,
mit Schraubbefestigung + Mutter

CODE 10506



SCHÄKEL | SHACKLE

HC2 3,25T 5/8-60

hochfest, geschweißt, verzinkt,
mit Schraubbefestigung + Mutter

CODE 10505



SCHÄKEL | SHACKLE

1T 3/8" BM

hochfest, geschweißt, schwarz,
mit Schraubbefestigung + Mutter

CODE 118648



SCHÄKEL | SHACKLE

2T 1/2" BM

hochfest, geschweißt, schwarz,
mit Schraubbefestigung + Mutter

CODE 118649



SCHÄKEL | SHACKLE

3,25T 5/8" BM

hochfest, geschweißt, schwarz,
mit Schraubbefestigung + Mutter

CODE 118650



CODE	Nenngröße	Tragfähigkeit bei 5facher Sicherheit	d1	d2	d3	d4	b1	b2	h2	Gewicht per Stück
	Zoll	kg	mm	mm	mm	mm	mm	mm	mm	ca. kg
10502	3/8	1000	10	11	25	7/16	16	26	36	0,14
10507	1/2	2000	13	16	30	5/8	21	33	48	0,33
10503	5/8	3250	16	19	40	3/4	27	43	60	0,65
10504	3/8	1000	10	11	25	7/16	16	26	36	0,20
10506	1/2	2000	13	16	30	5/8	21	33	48	0,37
10505	5/8	3250	16	19	40	3/4	27	43	60	0,71
118651	3/8	1000	10	-	26	12	16	36	-	0,14
118652	1/2	2000	13	16	30	5/8	21	33	48	0,33
118653	5/8	3250	16	19	40	3/4	27	43	60	0,71
118648	3/8	1000	10	11	25	7/16	16	26	36	0,14
118649	1/2	2000	16	19	40	3/4	27	43	60	0,65
118650	5/8	3250	13	16	30	5/8	21	33	48	0,33





www.GLOBALTRUSS.de